

# Geoprobe® Track-Mounted Direct Push Machines (Models 54LT, 54DT, 66DT, and 6610DT)

## Installation and Removal of a Rubber Track

This document describes the removal and installation of a rubber track on a Geoprobe® track-mounted direct push machine (Models 54LT, 54DT, 66DT, and 6610DT). Rubber tracks, just like truck tires, are wear items that must eventually be replaced. Using the procedures presented in this document, the operator can remove the old track assembly and install the new track assembly with common shop tools. The instructions may also be used to reinstall a thrown track in the field.

Note that the access plate and track tensioner of your machine may be located differently than shown in the illustrations of this document. This is merely a difference in the chassis configuration of the various models of track-mounted machines. The overall procedure is the same no matter whether the track tensioner is located toward the front or back of the track assembly.

It is recommended that only one rubber track be removed at a time. This will allow the operator to refer to the assembled track if a question should arise when installing the new rubber track.

### Required Equipment

- (1) Rubber Track (P/N: 11469 for Models 54DT, 66DT, and 6610DT; P/N:11440 for Model 54LT)
- (1) Ratchet Wrench, 3/8-inch drive
- (1) Socket Extension, 3/8-inch drive
- (1) Socket, 7/16-inch
- (1) Allen Wrench, 3/32-inch (will use to depress check ball - may use slightly smaller size if 3/32 not on hand)
- (1) Manual Grease Gun (do not use automatic grease gun)
- (1) Tape Measure or Ruler

### Track Removal

The machine must be raised off of the ground to allow removal of the track assembly. Fortunately, the foot and outriggers can provide the necessary lift.

1. Lower the foot and extend the outriggers to raise the tracks approximately 6 inches from the ground surface as shown in Figure 1.

**IMPORTANT: Your direct push machine can weigh several thousand pounds. Avoid injury in case of hydraulic failure by supporting the machine with blocks or jack stands after raising the tracks from the ground surface. Do not position yourself under the machine while performing this procedure.**

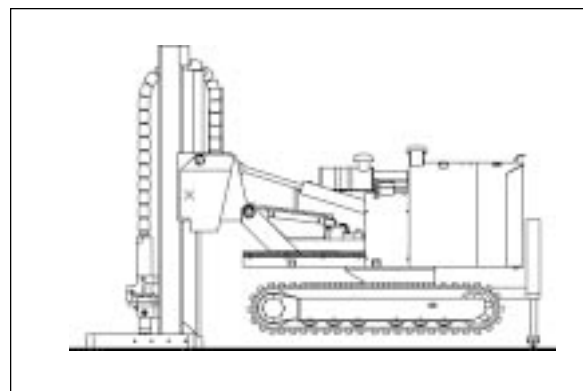

**Figure 1:** Tracks raised approximately 6 inches from the ground surface.

Track tension is provided by pumping grease into the tensioner assembly through a zirk located behind the tensioner cover plate (Fig. 2). The grease displaces a cylinder which pushes the tension wheel (Fig. 3) out from the track frame to tighten the rubber track. Grease must be relieved from within the tensioner to loosen the rubber track for removal.

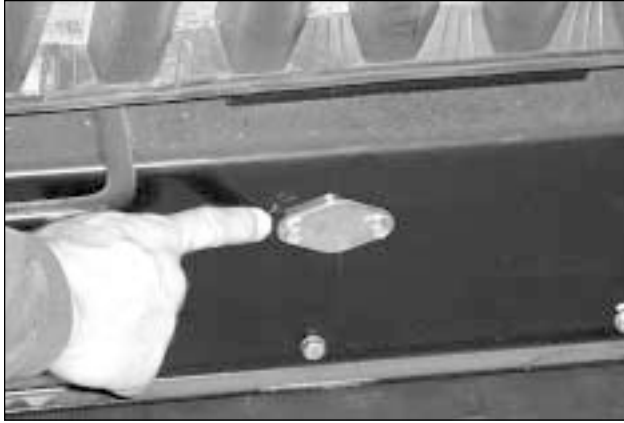
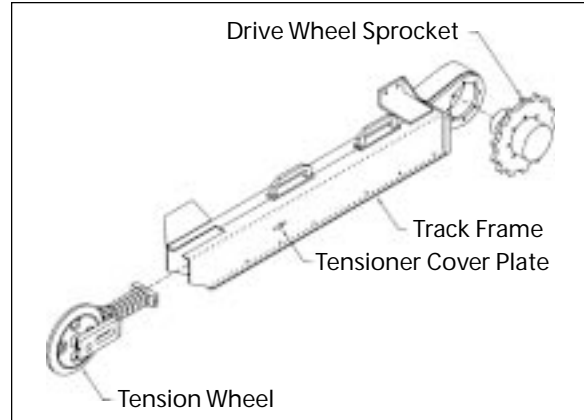

**Figure 2:** Tensioner cover plate located on track frame.

2. Remove the tensioner cover plate from the side of the track frame. The plate is diamond-shaped on 54DT, 66DT, and 6610DT machines (Fig. 2). Model 54LT machines will have a square cover plate.
3. Unthread the grease zirk from the track tensioner using the ratchet wrench, extension, and 7/16-inch socket (Fig. 4).
4. A check ball is located approximately 2 inches inside the tube from which the zirk was removed in Step 3. Depress the check ball using a 3/32-inch Allen wrench (Fig. 5) or other object of similar size. This will allow grease to escape from the track tensioner so that the track may be loosened for removal.
5. While continuing to depress the check ball in the grease tube, push down on the center of the rubber track with your foot. This should pull the tension wheel in toward the center of the track frame and loosen the rubber track. Grease will escape from the tube as shown in Figure 6.



**Figure 5:** Depress check valve to relieve tensioner.



**Figure 3:** Track assembly components.



**Figure 4:** Remove the grease zirk from the track tensioner.



**Figure 6:** Grease will escape from the tube as the tension wheel is retracted to loosen the tracks.

6. It may be necessary to have a second person help push down on the track in order to fully retract the tension wheel. The tension wheel is fully retracted when it contacts the track frame as shown in Figure 7. The rubber track can now be pried off of the frame.



**Figure 7:** The tension wheel will contact the track frame when fully retracted.

### Track Installation

The following procedure may be used to install a new rubber track or reinstall a thrown track as is best performed with two people.

The lugs of the rubber track are slightly V-shaped to increase traction. Geoprobe Systems® positions the rubber tracks on the machine to utilize the traction advantage during forward movement of the machine. The tracks are therefore installed with the center of the V-shaped lugs "pointing" toward the front of the machine when viewed from the top of the track.

1. Begin installation by placing the rubber track on the drive wheel sprocket as shown in Figure 8. The followers on the inside of the track should straddle the sprocket and will fit into the valleys between the sprocket teeth.
2. While a second person holds the middle of the rubber track up to the track frame, start the edge of the track over the tension wheel.
3. With the second person still holding the middle of the rubber track, push the track completely onto the tension wheel using your foot. The track followers should straddle the wheel.
4. Reinstall the grease zirk in the track tensioner grease tube (Fig. 9).



**Figure 8:** Place the rubber track over the drive wheel sprocket.



**Figure 9:** Reinstall the grease zirk with the ratchet, extension, and 7/16-inch socket.

5. Apply grease to the track tensioner to tighten the rubber track. Pump grease through the zirk using a hand-operated grease gun (Fig. 10). This extends the cylinder on the tensioner assembly which in turn moves the tension wheel out from the track frame and tightens the rubber track.

Occasionally measure track sag at the middle of the frame as shown in Figure 11. Stop pumping grease into the tensioner when the track sags 2.5-3.0 inches (or approximately 65-75 mm).

6. Start the machine engine and set it at idle rpm. Using the track control lever, rotate the rubber track in either direction for two or three revolutions. Shut off the engine.
7. Again measure track sag as shown in Figure 11. Be sure to measure at the point of greatest sag.
8. It is important to maintain proper track tension to prevent premature wear of the track assembly. If the track sags 2.5-3.0 inches (65-75 mm), continue with Step 9.

If the track sags more than approximately 3.0 inches or 75 mm, repeat Steps 5- 7 until the measured sag is within the specified range.

If the track sags less than approximately 2.5 inches or 65 mm, unthread the zirk from the grease tube and depress the check valve to release a small amount of grease from the tensioner. Operate the track and remeasure sag. Add or relieve grease until track sag is within the specified limits.

9. Replace the tensioner cover plate and tighten the two mounting bolts.
10. Remove the jack stands or blocks and lower the machine to the ground.



**Figure 10:** Pump grease into the track tensioner to tighten the rubber track.



**Figure 11:** The rubber track should sag 2.5-3.0 inches from the center of the track frame.



**-CORPORATE OFFICES-**

601 N. Broadway • Salina, KS 67401

1-800-436-7762 • Fax 785-825-2097

[www.geoprobe.com](http://www.geoprobe.com)

Geoprobe® and Geoprobe Systems®  
are Registered Trademarks of  
Kejr, Inc., Salina, Kansas

**COPYRIGHT 2002 by Kejr, Inc.  
ALL RIGHTS RESERVED**

No part of this publication may be reproduced or transmitted in any form or by any means, electronic or mechanical, including photocopy, recording, or any information storage and retrieval system, without written permission from Kejr, Inc.