

GEOPROBE® 2.0-IN. X 3.4-IN. OD PREPACKED SCREEN MONITORING WELLS

STANDARD OPERATING PROCEDURE

Document No. MK3172

PREPARED: July, 2009

REVISED: January, 2011

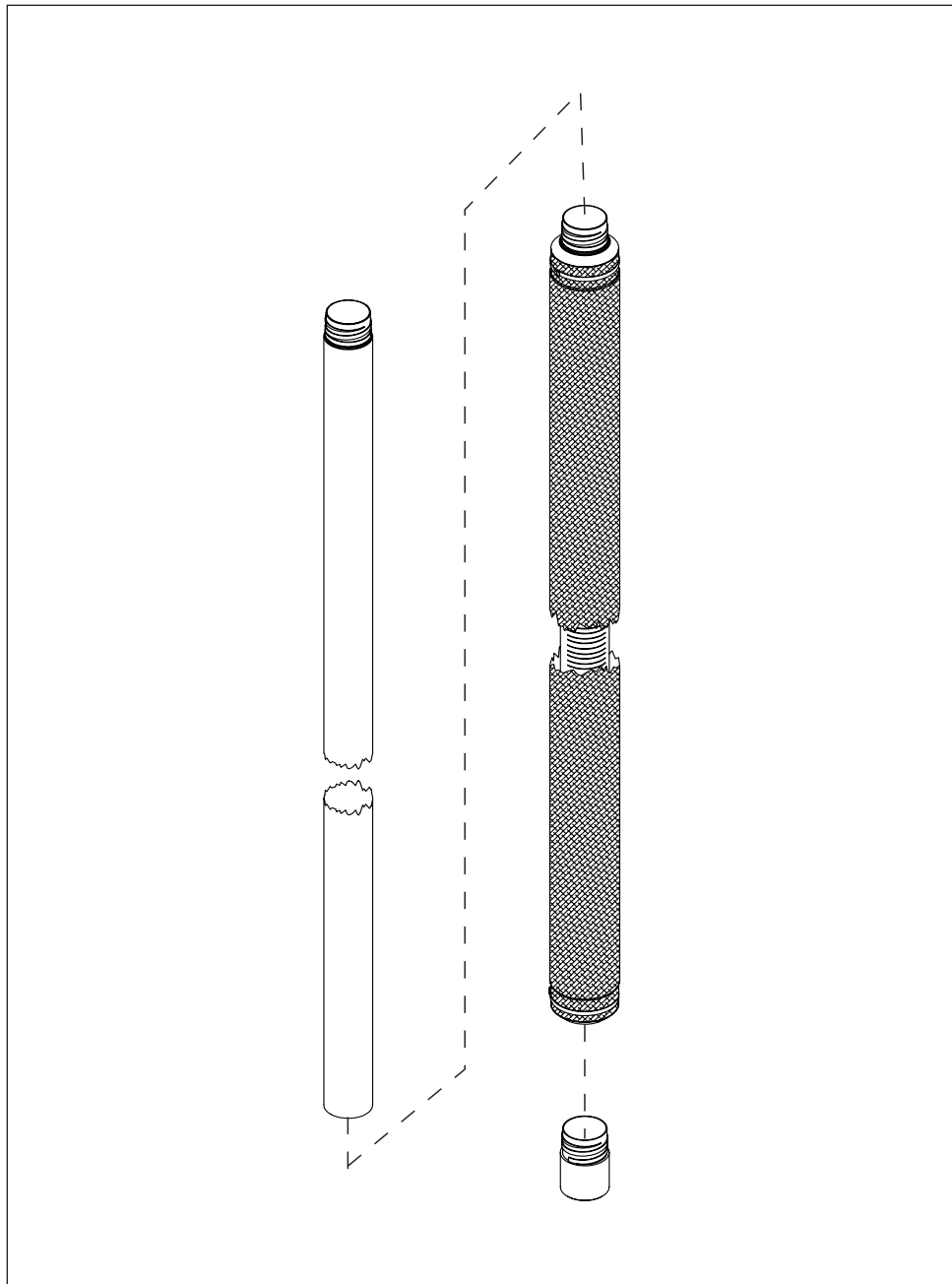

Geoprobe® 2.0-in. X 3.4-in. OD Prepacked Screen and 2.0-in. PVC riser



**Geoprobe® and Geoprobe Systems®, Macro-Core® and Direct Image® are
Registered Trademarks of Kejr, Inc., Salina, Kansas**

**Geoprobe® Prepacked Screens are manufactured under
U.S. Patent No. 7,735,553B2.**

© 2011 Kejr, Inc.

ALL RIGHTS RESERVED.

No part of this publication may be reproduced or transmitted in any form or by any means, electronic or mechanical, including photocopy, recording, or any information storage and retrieval system, without permission in writing from Kejr, Inc.

1.0 OBJECTIVE

The objective of this procedure is to install a permanent groundwater monitoring well for applications such as collecting water quality samples and conducting hydrologic and pressure measurements. These methods meet or exceed the specifications discussed for installation of permanent monitoring wells with prepacked screens in the U.S. Environmental Protection Agency's guidance document, "Expedited Site Assessment Tools For Underground Storage Tank Sites," (EPA, 1997) and ASTM Standards D6724 and D6725.

2.0 BACKGROUND

2.1 Definitions

Geoprobe® Subsurface Machine: A vehicle-mounted, hydraulically-powered machine that uses static force and percussion or rotation to advance tools into the subsurface for various applications including collecting soil core, soil gas, or groundwater samples. The Geoprobe® brand name refers to both machines and tools manufactured by Geoprobe Systems®, Salina, Kansas. Geoprobe® tools are used to perform soil core and soil gas sampling, groundwater sampling, soil conductivity and contaminant logging, grouting, materials injection, and to install permanent monitoring wells or temporary piezometers.

**Geoprobe® and Geoprobe Systems® are registered trademarks of Kejr, Inc., Salina, Kansas.*

2.0-inch x 3.4-inch OD Prepacked Well Screen (2.0-inch prepack): An assembly consisting of a slotted PVC pipe surrounded by environmental grade sand contained within a stainless steel wire mesh cylinder. The inner component of the prepacked screen is a flush-threaded, 2.0-inch schedule 40 PVC pipe with 0.01-inch (0.25-mm) slots. Stainless steel wire mesh with a pore size of 0.011 inches (0.28 mm) makes up the outer component of the prepack. The space between the inner slotted pipe and outer wire mesh is filled with 20/40 mesh silica sand. Geoprobe® 2.0-inch prepacks are available in nominal 5-foot (1.5-m) sections and have an outside diameter of 3.4 inches (86 mm) and a nominal inside diameter of 2.0 inches (51 mm).

2.2 Discussion

Conventional monitoring wells are typically constructed through hollow stem augers by lowering slotted PVC pipe (screen) to depth on the leading end of a string of threaded PVC riser pipe. A filter pack is then installed by pouring clean sand of known particle size through the tool string annulus until the slotted section of the PVC pipe is sufficiently covered.

Installing the entire filter pack through the tool string annulus becomes a delicate and time-consuming process when performed with direct push tooling due to the relatively small annulus. Sand must be poured very slowly in order to avoid bridging between the riser pipe and probe rod. When bridging does occur, considerable time can be lost in attempting to dislodge the sand or possibly pulling the tool string and starting over.

Prepacked screens greatly decrease the volume of loose sand required for well installation as each screen assembly includes the necessary sand filter pack. Sand must still be delivered through the casing annulus to provide a grout barrier extending at least 2 feet (0.6 m) above the top of the screen, but this volume is significantly less than for the entire screened interval.

The procedures outlined in this document describe construction of a 2.0-inch permanent groundwater monitoring well using Geoprobe® 2.0-inch x 3.4-inch outside diameter (OD) prepacked screens installed through 4.5-inch (114-mm) OD probe rods. Geoprobe® 2.0-inch prepacks have a running length of 5 feet (1.5 m) and are completed with 2.0-inch schedule 40 PVC riser pipe.

Installation of a prepack monitoring well begins by advancing 4.5-inch probe rods to depth with a Geoprobe® machine. Prepacked screen(s) are then assembled and installed through the 3.75-inch (95-mm) inside diameter (ID) of the probe rods using corresponding 2.0-inch schedule 40 PVC riser pipe (Fig. 2.1). Once the prepacks are lowered to depth, the rod string is slowly retracted until the leading end of the rods is approximately 3 feet (0.9 m) above the top prepack.

Regulations generally require a grout barrier that extends at least 2 feet (0.6 m) above the top prepack (Fig. 2.2) to avoid contaminating the well screens with bentonite or cement during installation. In some instances, natural formation collapse will provide the required barrier. If the formation is stable and does not collapse around the riser as the rod string is retracted, environmental grade 20/40 mesh sand must be installed through the probe rods to provide the minimum 2-foot grout barrier.

Granular bentonite or a high-solids bentonite slurry is installed in the annulus above the grout barrier to form a well seal at least 2 feet (0.6 m) thick (Fig. 2.2). A high-pressure grout pump (Geoprobe® GP Series Grout System) is then used to tremie a high-solids bentonite slurry or neat cement grout to fill the well annulus as the probe rods are retracted (Fig. 2.3). The grout mixture must be installed with a tremie tube from the bottom up to accomplish a tight seal without voids to meet regulatory requirements.

In certain formation conditions, the prepacked screens may bind inside the probe rods as the rods are retracted. This is most common in sandy formations sometimes called flowing or heaving sands. This binding can generally be overcome by lowering extension rods down the inside of the well riser and gently, but firmly, tapping the extension rods against the base of the well as the rods are slowly retracted. If the binding persists, clean tap water or distilled water may be poured down the annulus of the rods to increase the hydraulic head inside the well. This, combined with the use of the extension rods, will free up the prepacked screen and allow for proper emplacement.

Once the well is set, conventional flush-mount or aboveground well protection can be installed to prevent tampering or damage to the well head (Fig. 2.2). These wells can be sampled by several available methods (mechanical bladder pump, mini-bailer, Geoprobe® tubing check valve, etc.) to obtain high integrity water quality samples. These wells also provide accurate water level measurements and can be used as observation wells during aquifer pump tests.

When installed properly, Geoprobe® 2.0-inch prepacked screen wells generally meet regulatory requirements for a permanent monitoring well. While a detailed installation procedure is given in this document, it is by no means totally inclusive. **Always check local regulatory requirements and modify the well installation procedure accordingly.** These methods meet or exceed the specifications discussed for installation of permanent monitoring wells with prepacked screens in the U.S. Environmental Protection Agency's guidance document, "Expedited Site Assessment Tools For Underground Storage Tank Sites," (EPA, 1997) and ASTM Standards D6724 and D6725.

** The Mechanical Bladder Pump is manufactured under U.S. Patent No. 6,877,965 issued April 12, 2005.*

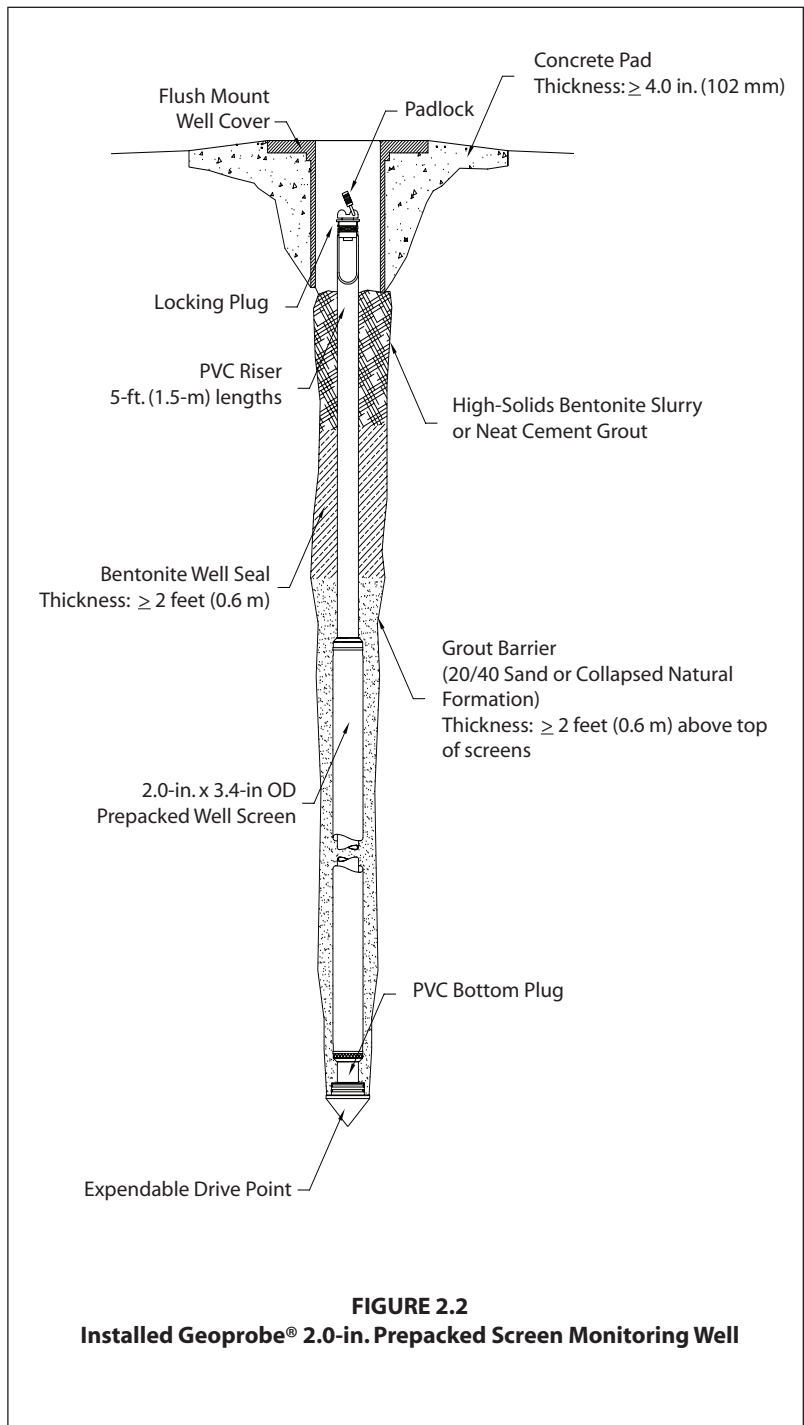
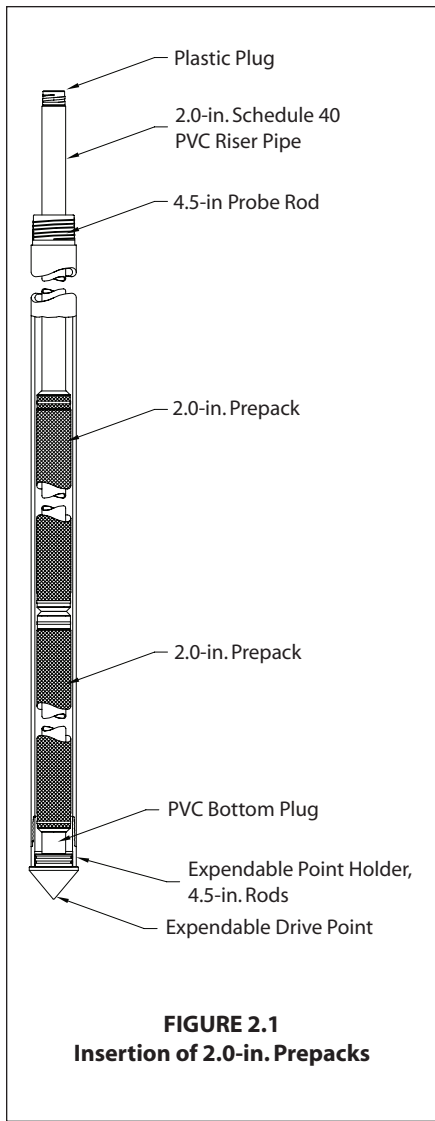

3.0 TOOLS AND EQUIPMENT

The following equipment is required to install a permanent monitoring well with Geoprobe® 2.0-inch prepacked screens. Refer to Figure 3.1 for an illustration of well components.

<u>2.0-in. Prepack Well Components</u>	<u>Part Number</u>
2.0-in. x 3.4-in. OD Prepacked Screen, 5-ft. length.....	32954
PVC Riser, 2.0-in. sch. 40, 5-ft. length.....	32320
Top Plug LDPE	34328
Locking Well Plug, for 2.0-in. sch. 40 riser	WP1720
PVC Bottom Plug, 2.0-in. sch. 40 flush thread	32456
Expendable Drive Point, 4.5-in. rods / 4.9-in. OD	36838

<u>Monitoring Well Accessories</u>	<u>Part Number</u>
Well Cover, flush-mount, 4-in. x 12-in., cast iron / ABS skirt	WP1741
Well Cover, flush-mount, 7-in. x 10-in., cast iron / galvanized skirt.....	WP1771
Sand, environmental grade (20/40 mesh), 50-lb. bag	AT95
Bentonite, granular (8 mesh), 50-lb. bag.....	AT91
Bentonite, powdered (200 mesh), 50-lb. bag.....	AT92

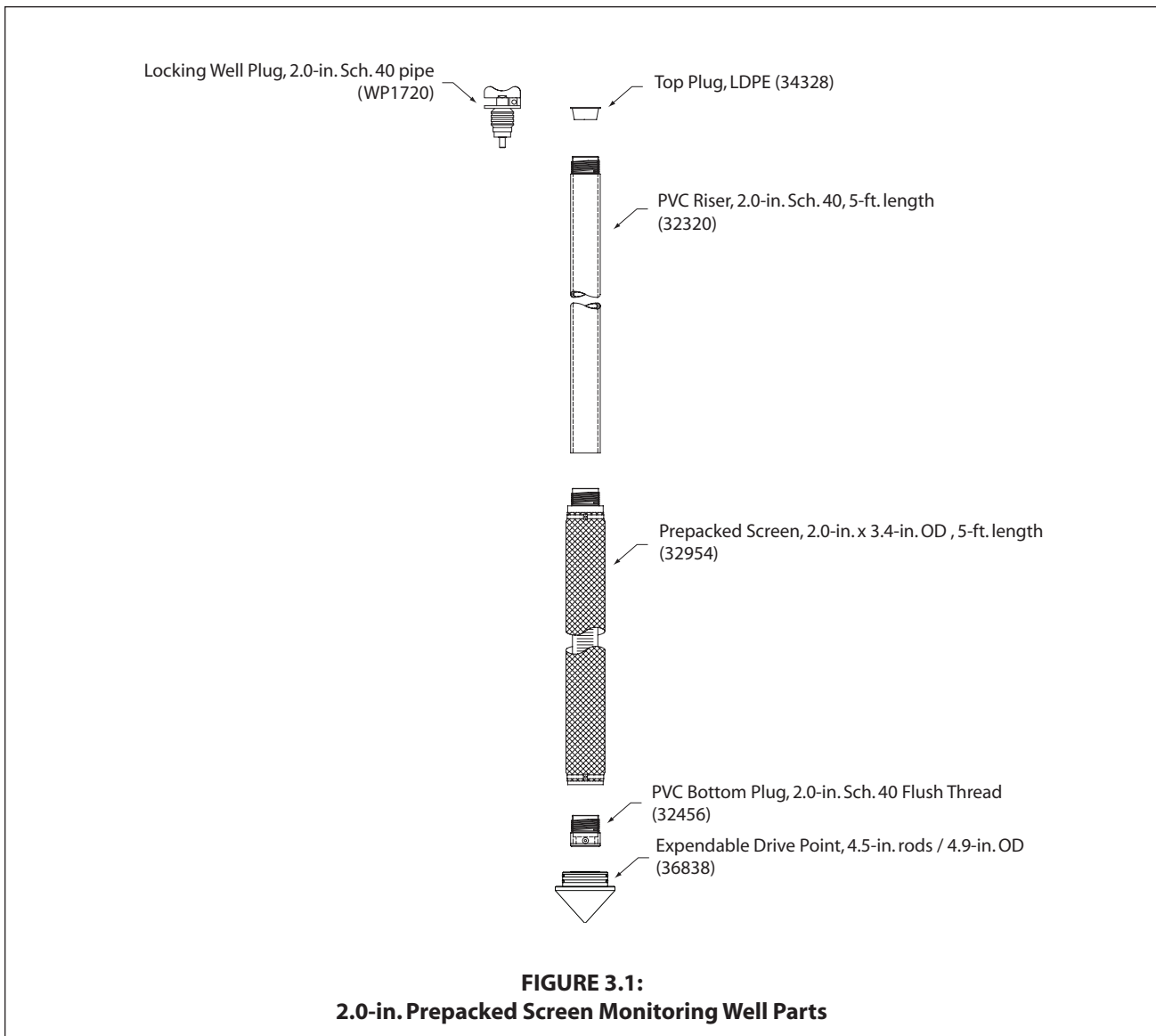

Geoprobe® Tools and Equipment	Part Number
Probe Rod, 4.5-in. x 48-in. or 60-in.....	25404 or 28887
Probe Rod, 4.5 in. x 1 meter (optional).....	34008
O-rinGP, 4.5-in. probe rods, Pkg. of 25.....	34900
Expendable Point Holder.....	36574
Expendable Point Assembly, Steel, 4.9-inch OD.....	36838
Drive Cap, Threadless, 4.5-inch Probe Rods (GH60 Series Hammer).....	26622
Rod Grip Pull Handle, 4.5-in. Probe Rods (GH60 Series Hammer).....	31909
Extension Rod, 48-in. or 60-in.....	AT671 or 10073
Extension Rod, 1-meter (optional).....	AT675
Extension Rod Coupler.....	AT68
Extension Rod Handle.....	AT69
Extension Rod Quick Links Pin.....	AT695
Extension Rod Quick Link Box.....	AT696
Screen Push Adapter.....	GW1535
GP Series Grout System.....	Varies
Water Level Meter, 0.438-in. OD Probe, 100-ft. Cable*.....	GW2000
Well Development Tool.....	29149
Stainless Steel Mini-Bailer (optional).....	GW41
Check Valve Assembly, 0.375-in. OD Tubing*.....	GW4210
Polyethylene Tubing, 0.375-in. OD, 500-ft. (for purging, sampling, etc.)*.....	TB25L
Mechanical Bladder Pump**.....	MB470
Low-Density Polyethylene Tubing, 0.625-in. OD, 100-ft. (for tremie tube grouting).....	16857
Grout Tubing Adapter, for 0.625-in. OD Tubing.....	16893

Additional Tools, Equipment, and Supplies

- Locking Pliers
- Pipe Wrench
- Volumetric Measuring Cup
- PVC Cutting Pliers
- Weighted Measuring Tape (optional)
- Small Funnel or Flexible Container (for pouring sand)
- Duct or Electrical Tape Roll
- Bucket or Tub (for dry grout material, water, and mixing)
- Portland Cement, Type I
- Concrete Mix (premixed cement and aggregate)
- Clean Water (of suitable quality for exposure to well components)

**Refer to Appendix A for additional tool options.*

***Refer to Standard Operating Procedure (SOP) for the Mechanical Bladder Pump (Technical Bulletin No. MK3013) for additional tooling needs.*

4.0 WELL INSTALLATION

Monitoring well installation can be divided into the six main tasks listed below. This section provides specific instructions for the completion of all six tasks.

- Driving the probe rods to depth
- Deploying the screen(s) and riser pipe
- Installing a sand/grout barrier
- Installing a bentonite seal above the screen
- Grouting the well annulus
- Installing surface protection

NOTE: The many prepacked screen options have resulted in an extensive list of Geoprobe® part numbers. To simplify the instructions presented in this document, part numbers for well components are not specified in the text. Refer to Section 3.0 for part numbers and complete descriptions for all well components and accessories.

4.1 Driving Probe Rods to Depth

Refer to Figure 4.1.

1. Place the Geoprobe® machine at the proposed monitoring well location and unfold the probe assembly into the operating position as instructed in the machine Owner's Manual. Because access to the top of the probe rod string is required, it is important to allow room for derrick retraction when positioning the unit for operation.

2. Place a new O-ring in the groove at the base of the male threads of an expendable point holder. Thread the point holder into a 4.5-in probe rod.

NOTE: O-rinGP must be installed at each probe rod joint to avoid cross-contamination during installation of the prepacked screen well.

3. A 4.9-inch OD expendable drive point assembly includes two O-rinGP. Ensure that both O-rinGP are installed on the point. Insert the point into the unthreaded end of the expendable point holder.

4. Place a drive cap over the threaded end of the 4.5-inch probe rod.

(continued on following page)

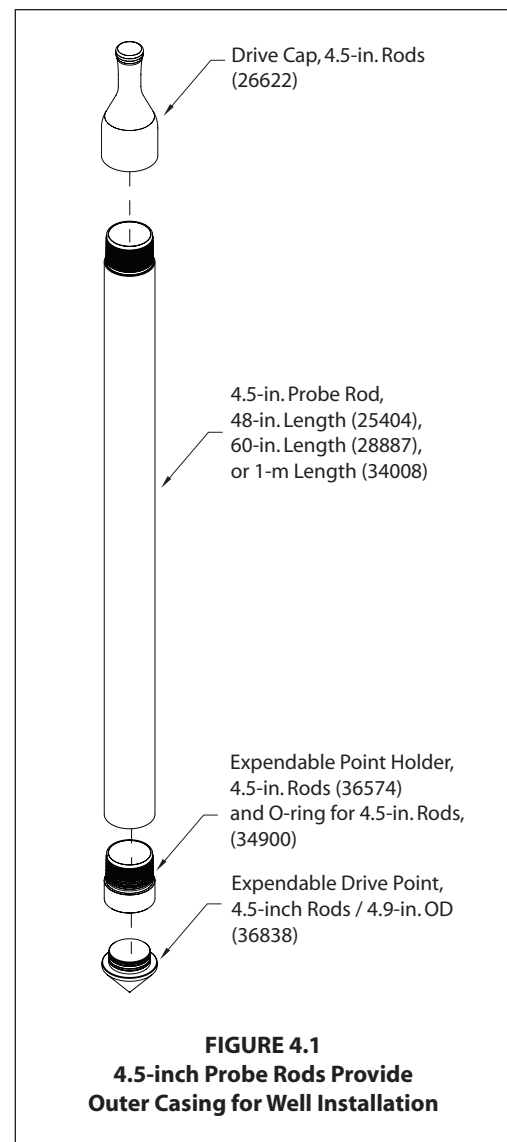

5. Position the probe rod assembly under the hydraulic hammer in the driving position (refer to machine Owner's Manual). Advance the probe rod into the ground the full stroke of the machine using percussion if necessary.

To install an accurately placed monitoring well, it is important to drive the rod string as straight as possible. If the first probe rod is not straight, retract the assembly from the ground and start over with Step 1.

6. Remove the drive cap from the probe rod.
7. Place a new O-ring in the groove at the base of the male threads of the probe rod.

NOTE: O-ring must be installed at each probe rod joint to avoid cross-contamination during installation of the prepacked screen well.

8. Thread another 4.5-inch probe rod onto the rod string.
9. Place the drive cap on the top probe rod and advance the rod string the full stroke of the machine.
10. Repeat Steps 6 thru 9 until the leading end of the expendable point holder is approximately 6 inches (15 cm) below the bottom of the desired screen interval. Over-driving by this distance accounts for the PVC bottom plug, the threads in the leading end of the prepack, and the "stem" of the expandable drive point. This places the slotted portion of the leading prepack at the bottom of the desired screen interval.

The top probe rod must extend above the ground surface far enough to allow gripping the rod string with the subsurface machine for pulling later in this procedure. It may be necessary to add another probe rod to achieve this height. Move the machine foot back to provide access to the top of the rod string.

4.2 Deploying the Screen(s) and Riser Pipe

1. With the probe rods driven to the proper depth, the next step is to deploy the prepacked screen(s) and riser pipe.
2. Thread a PVC Bottom Plug into a 2.0-inch prepack (Fig. 4.2).

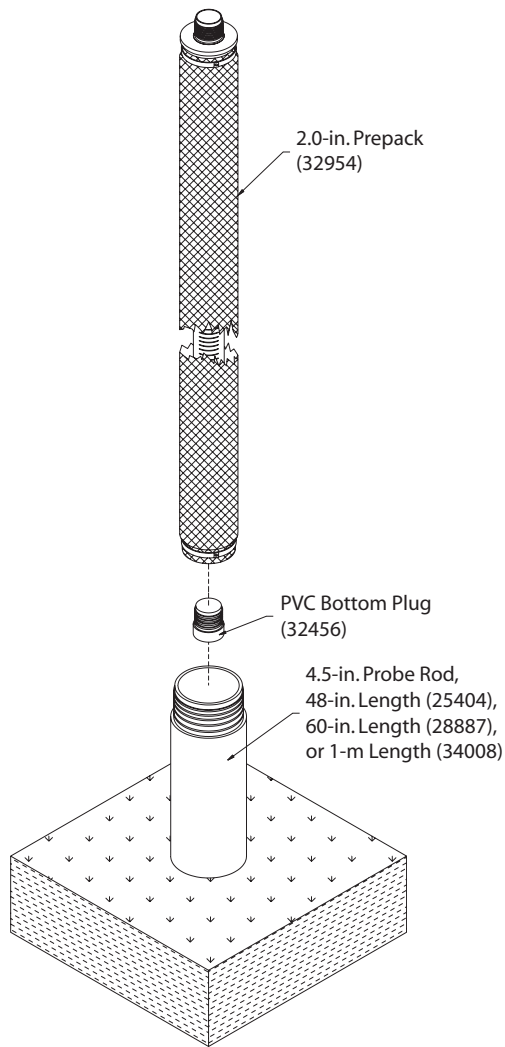

FIGURE 4.2
Prepacked Screen Assembly
Inserted Into Rod String

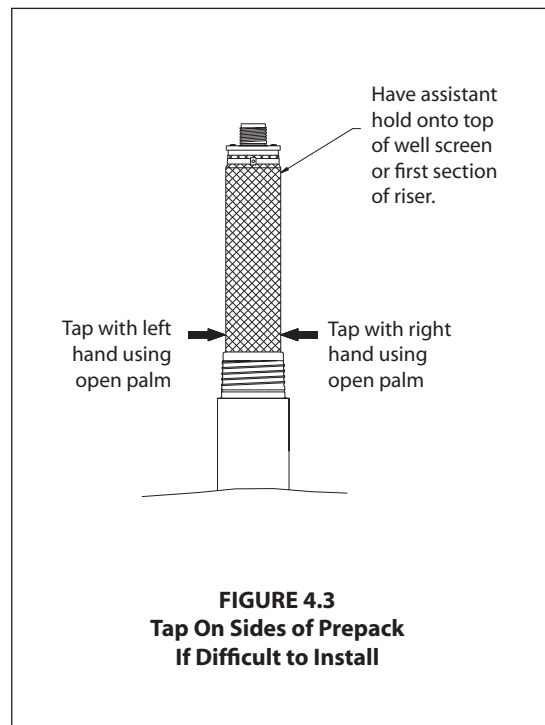

FIGURE 4.3
Tap On Sides of Prepack
If Difficult to Install

- Leading with the bottom plug, insert the prepacked screen assembly into the probe rod string as shown in Figure 4.2. If the prepack does not slide easily into the rods, do not force it. With the lower end of the prepack in the probe rod, tap the screen simultaneously with both hands using a clapping motion (Fig. 4.3). With this technique, the screen will drop by gravity into the probe rods. Have an assistant hold onto the top portion of the screen to prevent the screen from unexpectedly falling downhole.

CAUTION: Be careful when “kneading” the screen. Sudden screen slippage can pinch hands between the screen and the probe rod. To prevent screen slippage, have an assistant hold onto the prepack during the “kneading” operation.

- Add additional 5-foot prepacks to obtain the desired screened interval.
- With the assistance of a second person, attach five-foot sections of 2.0-inch schedule 40 PVC riser to the top of the screen assembly.

NOTE: O-rinGP are required at each riser joint to prevent groundwater from above the desired monitoring interval seeping into the well. Each stick of PVC riser is supplied with an O-ring installed at the base of the male threads. Ensure that the O-rinGP are in place when connecting the risers.

Continue adding riser sections until the leading screen reaches the bottom of the probe rods (Fig. 4.4). At least one foot (0.3 m) of riser should extend past the top probe rod. Place a plastic plug into the top riser. Duct tape may be used to help keep the plug in the riser.

- It is now time to pull up the probe rods from around the well screen and riser. Reposition the machine so that the Rod Grip Puller can be attached to the rod string.

(continued on Page 12)

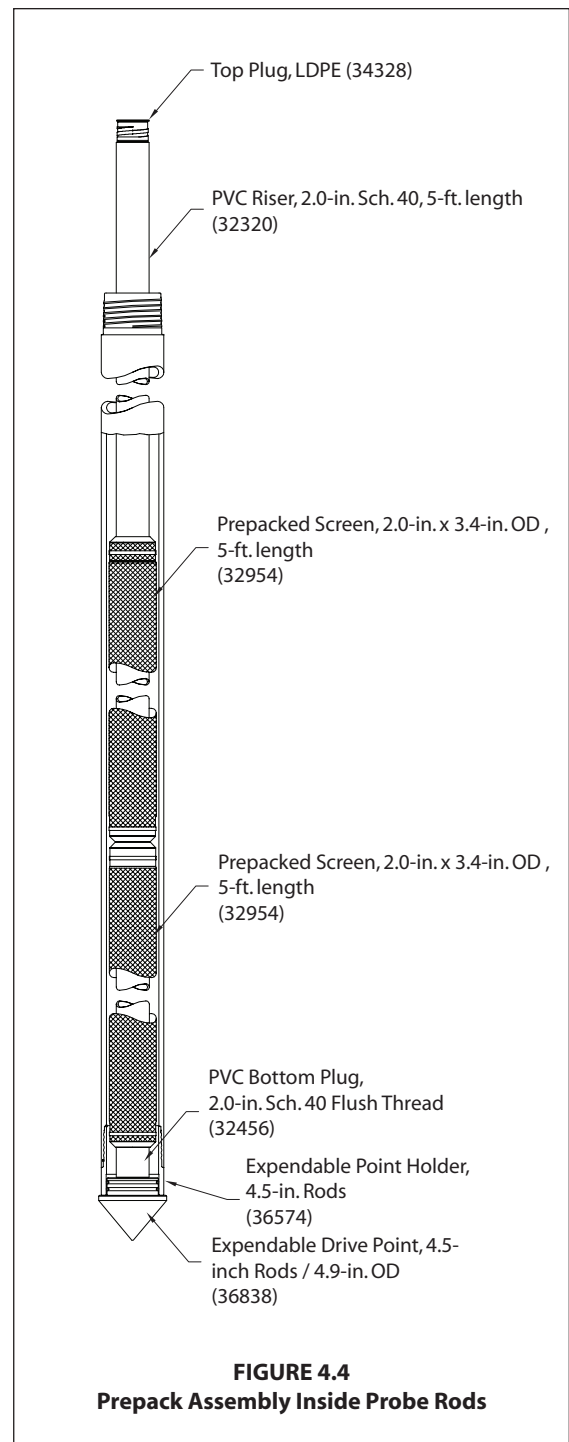

7. Retract the rod string the total length of all the screens plus an additional 3 feet (1 m). While pulling the rods, observe whether the top PVC riser stays in place or moves up with the rods.
 - a) If the riser stays in place, stable formation conditions are present. Continue retracting the rods to the depth specified above. Go to Section 4.3.
 - b) If the riser moves up with the probe rods, have a second person hold it in place while pulling up the rods. An additional section of PVC riser may be helpful. Once the probe rods have cleared the lower section of screen, the screen and riser assembly should stop rising with the rods. Continue retracting to the depth specified above. If the riser stays in place, go to Section 4.3.
 - c) If the risers continue to move up with the probe rods and cannot be held in place by hand, sand heave has most likely caused the screen to bind to the inside of the rods. Extension rods are now required. (Refer to Figure 4.5 for an illustration of extension rod accessories.)
 - i. Place a Screen Push Adapter on the end of an Extension Rod. Insert the adapter and extension rod into the PVC riser and hold either by hand or with an Extension Rod Jig. Attach additional extension rods with Extension Rod Couplers or Extension Rod Quick Links until the push adapter contacts the bottom of the screens (Fig. 4.6). Place an Extension Rod Handle on the top extension rod after leaving 3 to 4 feet (0.9 to 1.2 m) of extra height above the last probe rod.
 - ii. Slowly retract the probe rods while another person pushes and taps on the screen bottom with the extension rods (Fig. 4.6). To ensure proper placement of the screen interval and to prevent well damage, be careful not to get ahead while pulling the probe rods. The risers should stay in place once the probe rods are withdrawn past the screens. Retrieve the extension rods. Place the plug back into the top riser and secure it with duct tape if necessary.

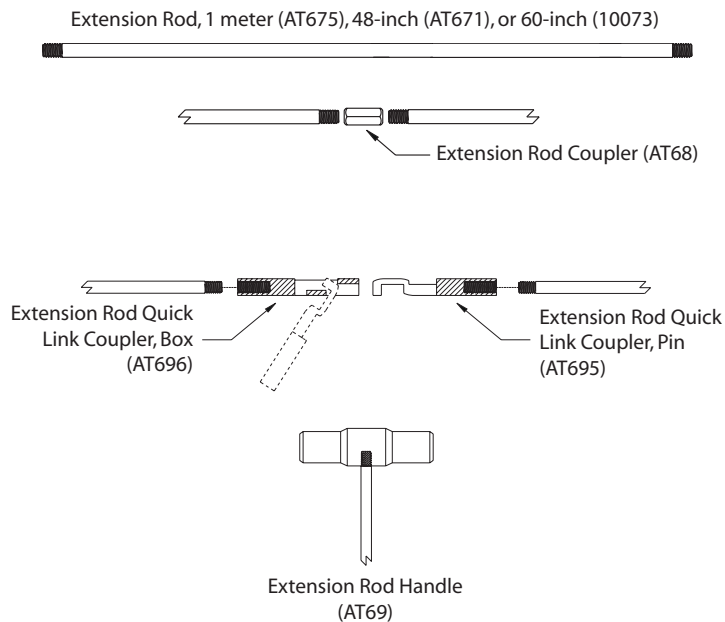

FIGURE 4.5
Geoprobe® Extension Rods and Accessories

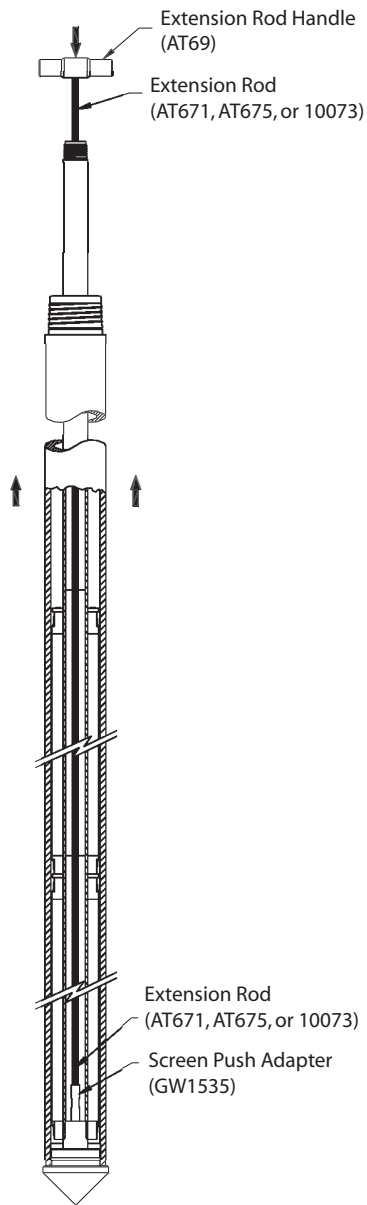

FIGURE 4.6
Using Extension Rods to Tap Out Wedged Screens

4.3 Installing the Grout Barrier

The natural formation will sometimes collapse around the well screens and PVC riser as the probe rod string is pulled back. This provides an effective barrier between the screens and grout material used to seal the well annulus. If the formation does not collapse, a sand barrier must be installed from the surface. This portion of the well installation procedure is important because an inadequate barrier will allow grout to reach the well screens. Grout contamination can produce non-representative samples and retard groundwater flow into the well.

1. Using a water level indicator or flat tape measure, determine the depth from the top of the PVC riser to the bottom of the riser and probe rod annulus. Two scenarios are possible:

a) Measured depth is 2 to 3 feet (0.6 to 0.9 m) less than riser length: This indicates that unstable conditions have resulted in formation collapse. A natural grout barrier was formed as material collapsed around the PVC riser when the probe rods were retracted. This commonly occurs in sandy formations. No further action is required. Proceed with Section 4.4 and perform Step 2 (unstable formation).

b) Measured depth is equal to or greater than riser length: This indicates that stable conditions are present. The probe hole has remained open and void space exists between the riser (and possibly the screen) and formation material. Clean sand must be placed downhole to provide a suitable grout barrier. Continue with Step 2.

2. Begin slowly pouring 20/40 mesh sand down the annulus between the PVC riser and probe rod string. Reduce spillage by using a funnel or flexible container as shown in Figure 4.7. Add approximately 2.5 gallons (9.5 L) for each 5-foot (1.5 m) screen section, plus 1.5 gallons (5.7 L) for a minimum 2-foot (0.6 m) layer of sand above the screen section.

Measure the annulus depth after each 1.5 gallons or 2 liters of sand. The sand may not fall all the way past the screen due to the tight annulus and possible water intrusion. This is acceptable, however, since the prepacked screens do not require the addition of sand. The important thing is that a sand barrier is provided above the screens.

Sand may also bridge within the annulus between the risers and probe rods and consequently fail to reach total depth (Fig. 4.7). This most likely occurs when the sand contacts the water table during deep well installations. Wet probe rods also contribute to sand bridging. If the annulus is open, skip to Section 4.4, Step 1. If bridging is evident, continue with Step 5.

3. In case of a sand bridge above the screens (wet rods, high water table, etc.), insert clean extension rods into the well annulus to break up the sand (Fig. 4.7). Simultaneously retracting the probe rods usually helps. Check annulus depth again. If sand is no longer bridged, proceed to Section 4.4. If bridging is still evident, continue with Step 6.
4. If the sand bridge cannot be broken up with extension rods, inject a small amount of clean water into the annulus using a Geoprobe® GP Series Grout System and 0.375-in. (9.5 mm) OD polyethylene tubing. Simply insert the poly tubing down the well annulus until the sand bridge is contacted. Attach the tubing to the grout machine and pump up to one gallon (4 L) of clean water while moving the tubing up and down. The jetting action of the water will loosen and remove the sand bridge. Check the annulus depth again. The distance should be 2 to 3 feet (0.6 to 0.9 m) less than the riser length. Proceed with Section 4.4.

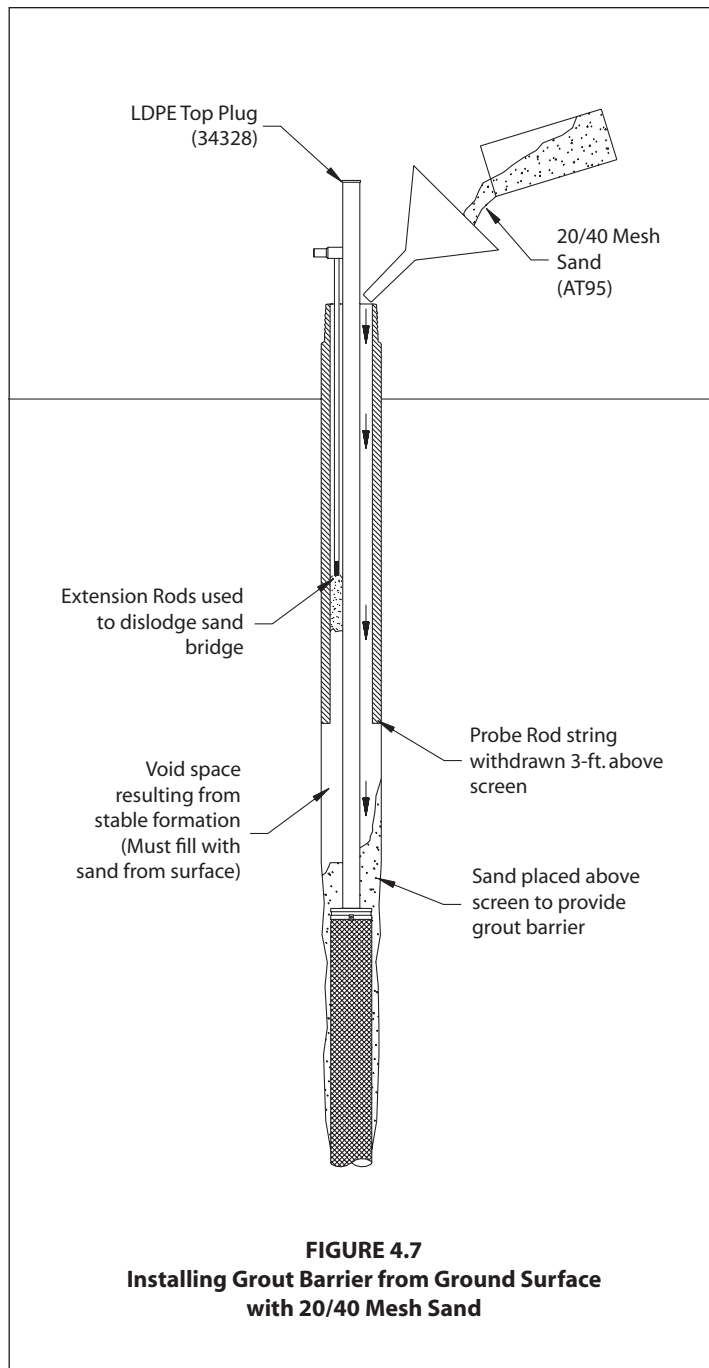

4.4 Bentonite Seal Above Screen

Bentonite is an expanding clay which exhibits very low permeability. When properly placed, bentonite prevents contaminants from moving into the well screens from above the desired monitoring interval. The seal is formed either by pouring granular bentonite into the annulus from the ground surface, or by injecting a high-solids bentonite slurry directly above the grout barrier. The use of granular bentonite is limited to cases in which the top of the screen ends above the water table (no water is present in the probe rods). Whichever method is used, at least 2 feet (0.6 m) of bentonite must be placed above the sand pack.

1. Stable Formation. Granular bentonite is recommended if the following conditions are met:

- Top of screen interval is above the water table
- Formation remained open when probe rods were retracted
- Bridging was not encountered while installing sand for the grout barrier in Section 4.3.

a) Withdraw the probe rod string another 3 to 4 feet (0.9 to 1 m) and ensure that the PVC riser does not lift with the rods. It is important that the bottom of the rod string is above the proposed seal interval. If positioned too low, dry bentonite will backup into the expendable point holder. Bridging then results if moisture is present inside the probe rods.

b) Pour bentonite between the probe rods and PVC riser as was done with the sand in Section 4.3. To properly hydrate the granular bentonite, it is necessary to periodically add water through a tremie tube while installing the bentonite. To accomplish this, repeat adding 6 inches (15 cm) of granular bentonite followed by 2 gallons (8 L) of water through a tremie tube until a minimum 2-foot (0.6 m) bentonite layer is created. Use the following procedure:

i. Pour 0.4 gallons (1.5 L) of granular bentonite into the annulus. This volume of bentonite will fill approximately 6 inches (15 cm) of annular space.

ii. Check for bridging inside the annulus. Measure the riser depth to the bottom of the annulus. The depth should equal the riser length minus the 2-foot sand pack and the added bentonite. If the measured depth is significantly less than expected, the bentonite has more than likely bridged somewhere inside the rod string. A procedure similar to that identified for bridged sand (Section 4.3, Steps 5 and 6) may be used to dislodge the granular bentonite.

iii. Hydrate the bentonite by adding 2 gallons (8 L) of water to the annulus through a tremie tube. Do not pour water directly into the annulus. A tremie tube will help prevent bridging by keeping the rod string dry.

iv. Repeat this procedure an additional three times or until the 2-foot (0.6 m) thick bentonite layer is completed.

2. Unstable formation. A grout machine is required to install the bentonite seal if the formation collapsed when the rods were retracted or the sand bridged when installing the grout barrier. The grout machine can pump a high-solids bentonite slurry under sufficient pressure to displace collapsing soil. Void spaces often develop when poured (gravity installed) granular bentonite is used under these conditions, resulting in an inadequate annular seal. Wet rods will often lead to bridging problems as well. Use the procedure on the following page to install a bentonite seal with a grout pump.

a) Mix 3 gallons (11 L) of high-solids bentonite (20% to 25% solids by dry weight) and place in the hopper of the grout machine.

b) Insert flexible tubing to the bottom of the annulus between the probe rods and well riser. Leaving at least 25 feet (8 m) extending from the top of the rod string, connect the tubing to the grout machine. This extra length will give needed slack for rod extraction (completed later in the procedure).

NOTE: The side-port tremie method is recommended to prevent intrusion of grout into the sand barrier. To accomplish side-port discharge of grout, cut a notch approximately one inch (25 mm) up from the leading end of the tubing and then seal the leading end with a threaded plug of suitable size.

c) Reposition the machine and attach a rod grip puller.

d) Activate the grout pump and fill the tremie tube with bentonite. Begin slowly pulling the rod string approximately 3 feet (1.0 m) while operating the pump (Fig.4.8). This will place bentonite in the void left by the retracted rods before it is filled by the collapsing formation. Continue to watch that the PVC riser does not come up with the rod string.

NOTE: When removing the retracted probe rod, slide the rod over the tremie tube and place it on the ground next to the grout machine. This eliminates cutting and reattaching the tubing for each rod removed from the string. Take care not to “kink” the tremie tube during this process as it will create a weak spot which may cause the tubing to burst when pressure is applied.

e) Measure the annulus depth to ensure that at least 2 feet (0.6 m) of bentonite was delivered. Pump additional bentonite slurry if needed.

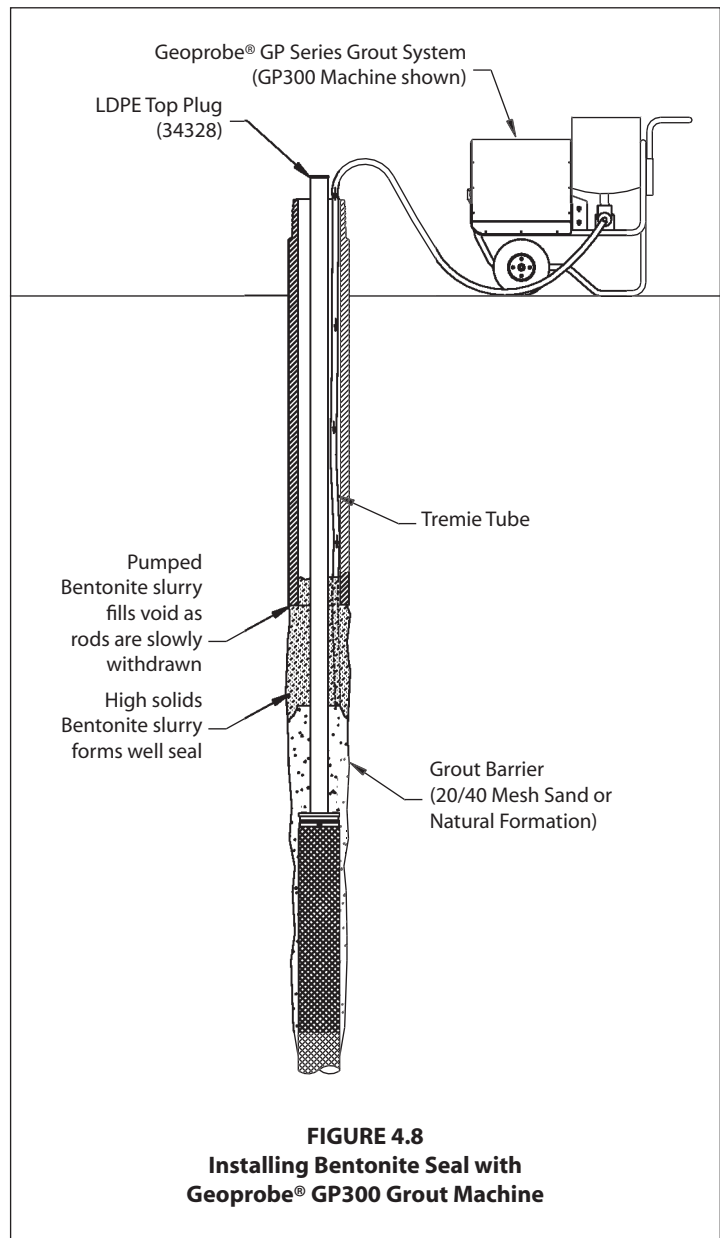

FIGURE 4.8
Installing Bentonite Seal with
Geoprobe® GP300 Grout Machine

4.5 Grouting the well annulus

The placement of grout material within the remaining well annulus provides additional protection from vertical contaminant migration. Most grout mixes are composed of neat cement, high-solids bentonite slurry, or a combination of cement and bentonite. Such mixes must be delivered with a high-pressure grout pump. When stable formations exist, the well may be sealed by pouring dry granular bentonite directly into the annulus from the ground surface. Consult the appropriate regulatory agency to determine approved grouting methods. This section presents the procedure for grouting the well annulus with a Geoprobe® GP Series Grout System. Refer to Figure 4.9 as needed.

1. Mix an appropriate amount of grout material and place it in the hopper of the grout machine.

NOTE: It is recommended that an additional 20 to 25 percent of the calculated annulus volume be added to the total grout volume. This additional amount allows for grout that either remains in the grout hose or moves into the formation during pumping. Including an additional 20 percent, it will take approximately 0.9 gallons (3.4 L) of grout for each foot of riser below ground surface.

2. Insert tremie tube into the well annulus until the end of the flexible tubing reaches the top of the bentonite seal. Ensure that at least 25 feet (8 m) of tubing extends from the top of the rod string. This extra length allows rod retraction with the tubing attached to the pump.
3. Attach the tubing to the grout machine and begin pumping. If the bentonite seal was below the water table (deep well installation), water will be displaced and flow from the probe rods as the annulus is filled with grout. Continue operating the pump until undiluted grout flows from the top probe rod.
4. Reposition the subsurface machine and prepare to pull rods.
5. Begin pulling the probe rods while continuing to pump grout. Match the pulling speed to grout flow so that the rods remain filled to the ground surface. This maintains hydraulic head within the probe rods and ensures that the void left by the withdrawn rods is completely filled with grout.

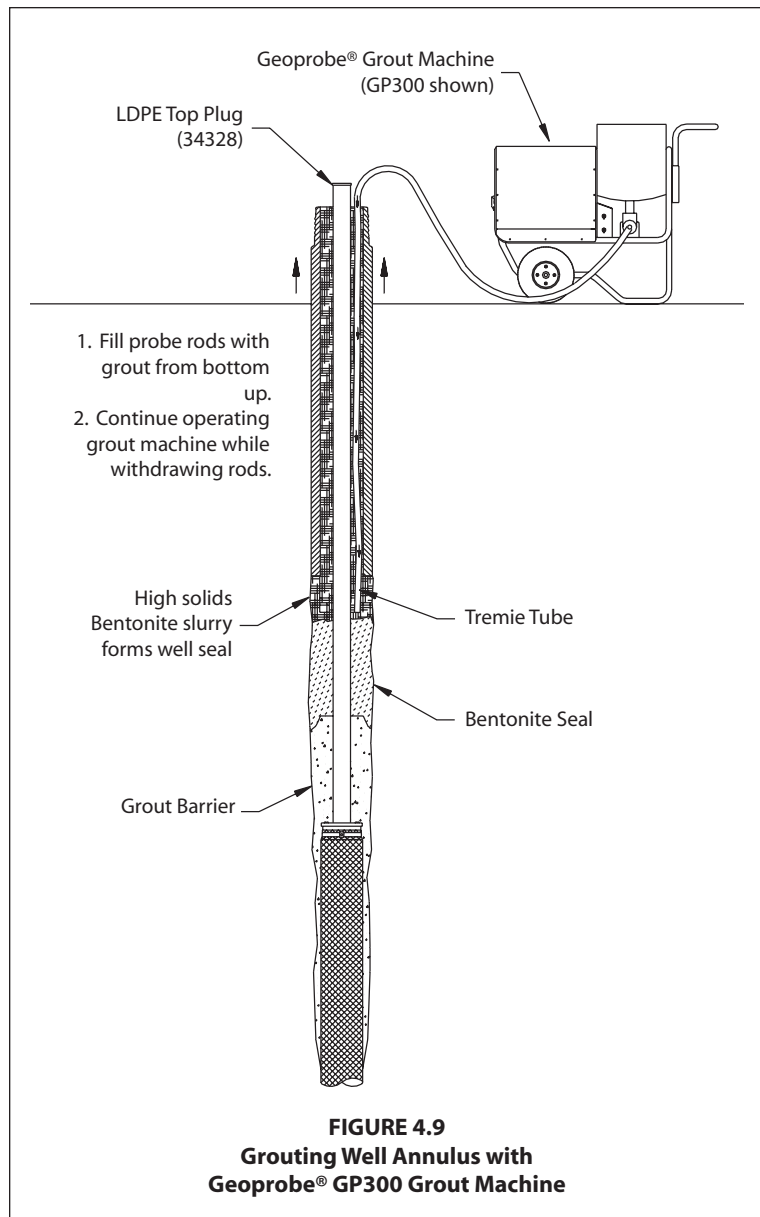

NOTE: Slide the probe rods over the tremie tube and place neatly on the ground next to the grout machine. Be careful to not pinch or bind the flexible tubing as this forms weak spots which may burst when pressure is applied.

NOTE: Try to avoid filling the upper 12 inches (305 mm) of well annulus with grout when pulling the expendable point holder. This will make for a cleaner well cap installation.

6. When all probe rods have been retrieved and the well is adequately grouted, unstring the tremie tube and begin cleanup. It is important to promptly clean the probe rods, grout machine, and accessories. This is especially true of cement mixes as they quickly set up and are difficult to remove once dried.

4.6 Surface Cover/Well Protection

A surface cover protects the PVC well riser from damage and tampering. Although aboveground and flush-mount well covers may be used, most Geoprobe® monitoring wells have been installed with flush-mount covers (Fig. 4.10 - Page 20). Consult the project planners and/or appropriate regulators to determine the approved well cover configuration for your specific application.

1. In order to fit under a flush-mount cover, the top of the well riser must be below the ground surface. Place the well cover over the riser and push it into the ground to mark the cover diameter. Remove the cover and dig out approximately 6 inches (152 mm) of soil from within the cover mark.
2. Remove the LDPE top plug from the PVC riser. The top of the riser should be approximately 4 inches (102 mm) above the bottom of the hole. If a joint is near this level, unthread the top riser. If a joint is not positioned near the specified level, cut off the riser with PVC cutters.

IMPORTANT: Do not cut off the riser with a hacksaw as cutting will fall down into the screens.

3. Insert a locking well plug into the top of the PVC riser. Tighten the center wing-bolt on the plug until it fits snugly within the riser. Secure the well plug by installing a padlock over one side of the wingbolt and through the hole provided on top of the plug.
4. Position the well cover so that it is centered over the PVC pipe. Push the cover into the ground using the machine foot if needed. Provide at least 0.5 inches (13 mm) of space between the top of the locking cap and bottom of the well cover lid. Do not push the cover so deep as to place the top of the lid below the surrounding ground surface.
5. Support the well cover by installing a concrete pad according to project requirements. Pads are commonly square-shaped with a thickness of 4 inches (102 mm) and sides measuring 24 inches (610 mm) or greater. Finish the pad so that the edges slope away from the center to prevent ponding of surface water on the well cover.
6. Fill the inside of the well cover with sand up to approximately 2 to 3 inches (51 to 76 mm) from the top of the PVC riser.

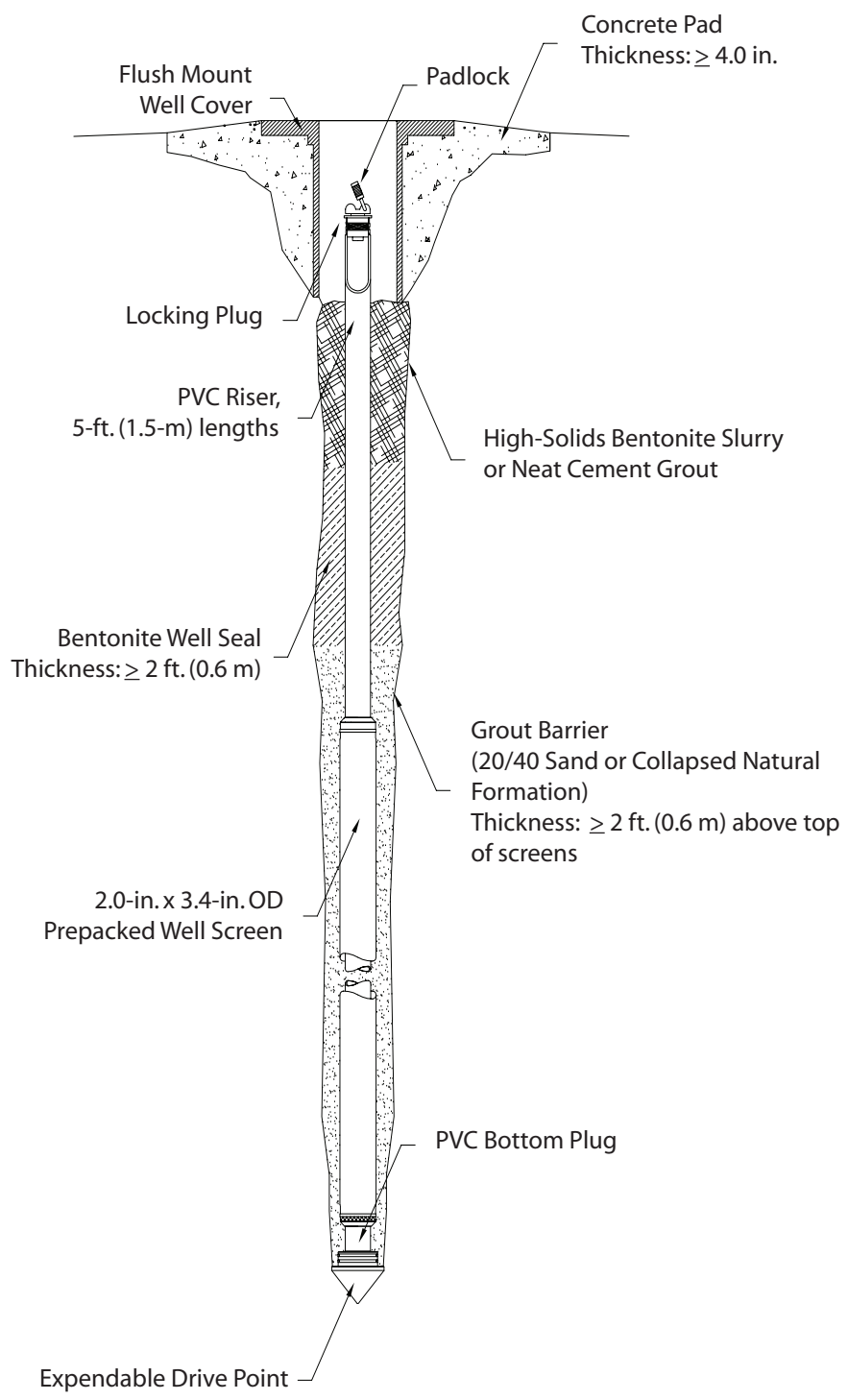

FIGURE 4.10
Properly Installed Geoprobe® 2.0-inch Prepacked Screen Monitoring Well

5.0 WELL DEVELOPMENT

"The development serves to remove the finer grained material from the well screen and filter pack that may otherwise interfere with water quality analyses, restore groundwater properties disturbed during the installation (probing) process, and to improve the hydraulic characteristics of the filter pack and hydraulic communication between the well and the hydrologic unit adjacent to the well screen," (ASTM D5092).

The two most common methods of well development are purging (bailing or pumping) and mechanical surging.

5.1 Purging involves removing at least three well volumes of water with either a Tubing Bottom Check Valve (Fig. 5.1), Stainless Steel Mini-Bailer Assembly or Mechanical Bladder Pump.

Include the entire 4.9-inch (124-mm) diameter of disturbed soil at the screen interval when calculating the well volume. Using this diameter, the well volume is approximately 4.9 gallons (19 L) for each 5-foot (1.5-m) long screen.

5.2 Mechanical Surging uses a surge block which is attached to extension rods and lowered inside the riser to the screen interval. The extension rods and surge block are moved up and down, forcing water into and out of the screen. Water and loosened sediments are then removed using one of three methods listed in 5.1.

IMPORTANT: Mechanical surging may damage the well screen and/or reduce groundwater flow across the filter pack if performed incorrectly or under improper conditions. Refer to ASTM D5521, "Standard Guide for Development of Groundwater Monitoring Wells in Granular Aquifers" for a detailed discussion of mechanical surging.

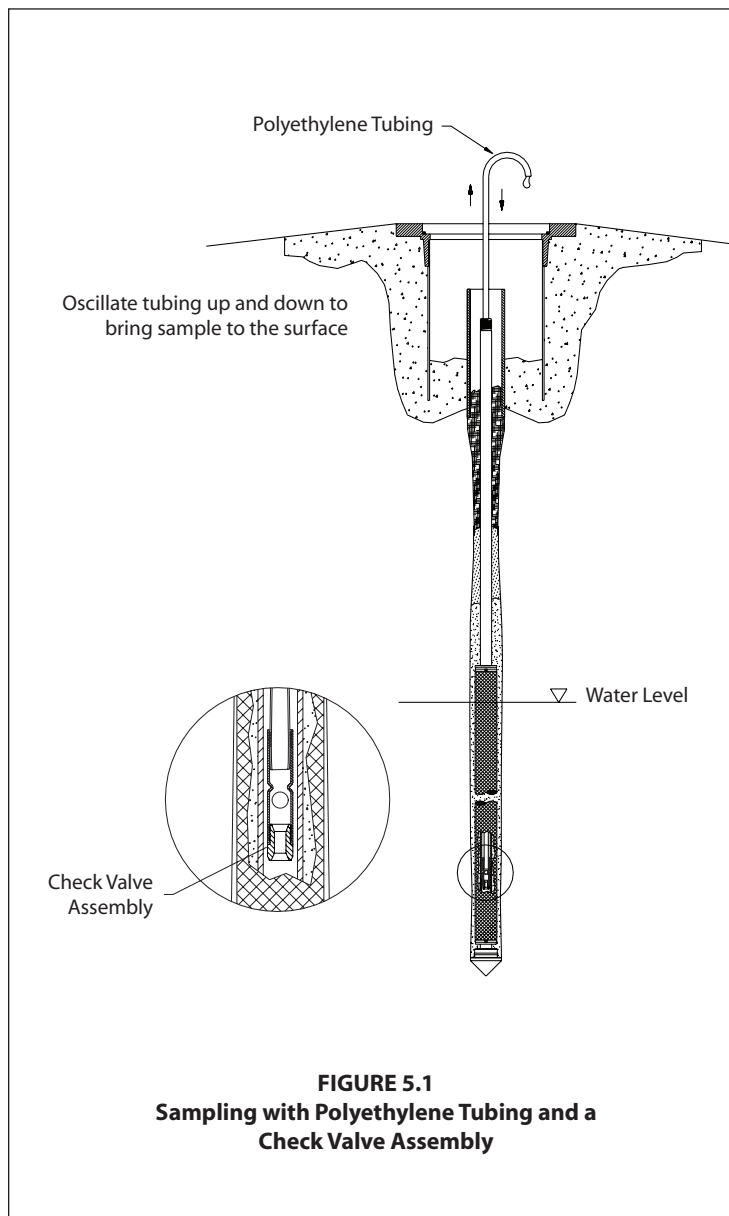

Development should continue until consecutive samples yield representative water. "Representative water is assumed to have been obtained when pH, temperature, and specific conductivity readings stabilize and the water is visually clear of suspended solids," (ASTM D5092).

6.0 SAMPLE COLLECTION

The federal EPA and many state agencies are recommending or requiring use of the "low-flow" sampling protocol (EPA 1996). This method is preferred when sampling for volatile contaminants or metal analytes. The Geoprobe® MB470 Mechanical Bladder Pump may be used to meet requirements of the low-flow sampling protocol (EPA 1996).

The Mechanical Bladder Pump can be used with any of the available flow-through-cells and water quality monitoring probes. Smaller volume flow-through-cells are recommended when available. Use of the Mechanical Bladder Pump and flow-through-cell allows you to meet the stringent requirements for monitoring pH, specific conductance, DO, and ORP, and obtaining low-turbidity samples for metals analysis.

Groundwater samples may also be collected with poly tubing and a check valve assembly (Fig.6.1) or a stainless steel mini-bailer assembly when appropriate. While the check valve is the quicker and more economical sampling device, some operators still prefer the traditional mini-bailer.

Before going into the field to sample monitoring wells (or groundwater samplers), be sure to know the level of sample quality that will be required. For high-integrity samples that must meet strict data quality objectives, sampling with a mechanical bladder pump may be required. Conversely, if screening level data is required (is it there and about how much?) a check valve assembly may be sufficient and could save time and money. For further information on this topic, request the Geoprobe® bulletin titled "Groundwater Quality and Turbidity vs. Low Flow."

7.0 REFERENCES

ASTM Standard D5092, 2004e1, "Standard Practice for Design and Installation of Ground Water Monitoring Wells in Aquifers," ASTM International, West Conshohocken, PA, 2004, DOI: 10.1520/D5092-04E01, www.astm.org

ASTM Standard D5521, 2005, "Standard Guide for Development of Ground Water Monitoring Wells in Granular Aquifers," ASTM International, West Conshohocken, PA, 2005, DOI: 10.1520/D5521-05, www.astm.org

ASTM Standard D6724, 2004, "Standard Guide for Selection and Installation of Direct Push Ground Water Monitoring Wells," ASTM International, West Conshohocken, PA, 2004, DOI: 10.1520/D6724-04, www.astm.org.

ASTM Standard D6725, 2004, "Standard Practice for Direct Push Installation of Prepacked Screen Monitoring Wells in Unconsolidated Aquifers," ASTM International, West Conshohocken, PA, 2004, DOI: 10.1520/D6725-04, www.astm.org

Geoprobe Systems®, 2003. "Tools Catalog," V.6.

U.S. Environmental Protection Agency (EPA), 1996. Robert W. Puhls and Michael J. Barcelona. "Ground Water Issue: Low-Flow (Minimal Drawdown) Ground-Water Sampling Procedures." OSWER. EPA/540/S-95/504. April.

U.S. Environmental Protection Agency (EPA), 1997. "Expedited Site Assessment Tools For Underground Storage Tank Sites: A Guide for Regulators." EPA 510-B-97-001. March, 1997.

**APPENDIX A
ALTERNATIVE PARTS**

<u>Groundwater Purging and Sampling Accessories</u>	<u>Part Number</u>
Polyethylene Tubing, 0.25-inch OD, 500 ft.....	TB17L
Polyethylene Tubing, 0.5-inch OD, 500 ft.....	TB37L
Polyethylene Tubing, 0.625-inch OD, 50 ft.....	TB50L
Check Valve Assembly, 0.25-inch OD Tubing.....	GW4240
Check Valve Assembly, 0.5-inch OD Tubing	GW4220
Check Valve Assembly, 0.625-inch OD Tubing	GW4230
Water Level Meter, 0.375-inch OD Probe, 100-ft. cable	GW2001
Water Level Meter, 0.438-inch OD Probe, 200 ft. cable	GW2002
Water Level Meter, 0.375-inch OD Probe, 200-ft. cable	GW2003
Water Level Meter, 0.438-inch OD Probe, 30-m cable.....	GW2005
Water Level Meter, 0.438-inch OD Probe, 60-m cable.....	GW2007
Water Level Meter, 0.375-inch OD Probe, 60-m cable.....	GW2008
Well Development Tool	29149

Equipment and tool specifications, including weights, dimensions, materials, and operating specifications are subject to change without notice. Where specifications are critical to your application, please consult Geoprobe Systems®.

Geoprobe Systems[®]

A DIVISION OF KEJR, INC.

Corporate Headquarters

1835 Wall Street • Salina, Kansas 67401
1-800-GEOPROBE (1-800-436-7762) • Fax (785) 825-2097
www.geoprobe.com



GET THE LATEST VERSION OF THIS DOCUMENT