

Geoprobe® 8150LS Rotary Sonic Rig

Rotary Sonic Drill Rigs | 8150LS

Maximize Output in Mixed Formations

Drillers seeking to handle tough site conditions with a single drill rig while preserving the option for sampling and setting wells rely on the 8150LS sonic drilling rig to quickly provide continuous, undisturbed core samples to impressive depths in a wide range of formations.

VIDEOS AVAILABLE AT GEOPROBE.COM/8150LS WHEN YOU SEE THIS SYMBOL

Dual Winch System

- Standard winch: 2,500 lbs. of pull
- Optional secondary winch: 1,800 lbs. of pull

Geoprobe® GV5 Sonic Head

- 50K Dynamic Force
- 150 Hz

Multi-Function Drill Mast

- High-speed coring head (optional)
- Optional auto drop hammer

Head Centerline Side-Shift, Extend, Drill Mast Dump, Breakout Vertical Shift, Head Tilt

Rock Coring Compatible

Engine-Mounted Air Compressor

Rod Handler

Water / Mud Pumps

- Multiple configurations available

14-inch Double Wrench Breakout

Control Panel

- Movable, adjustable swing arm
- Remote diagnostics

Outriggers (Four Point Stabilization)

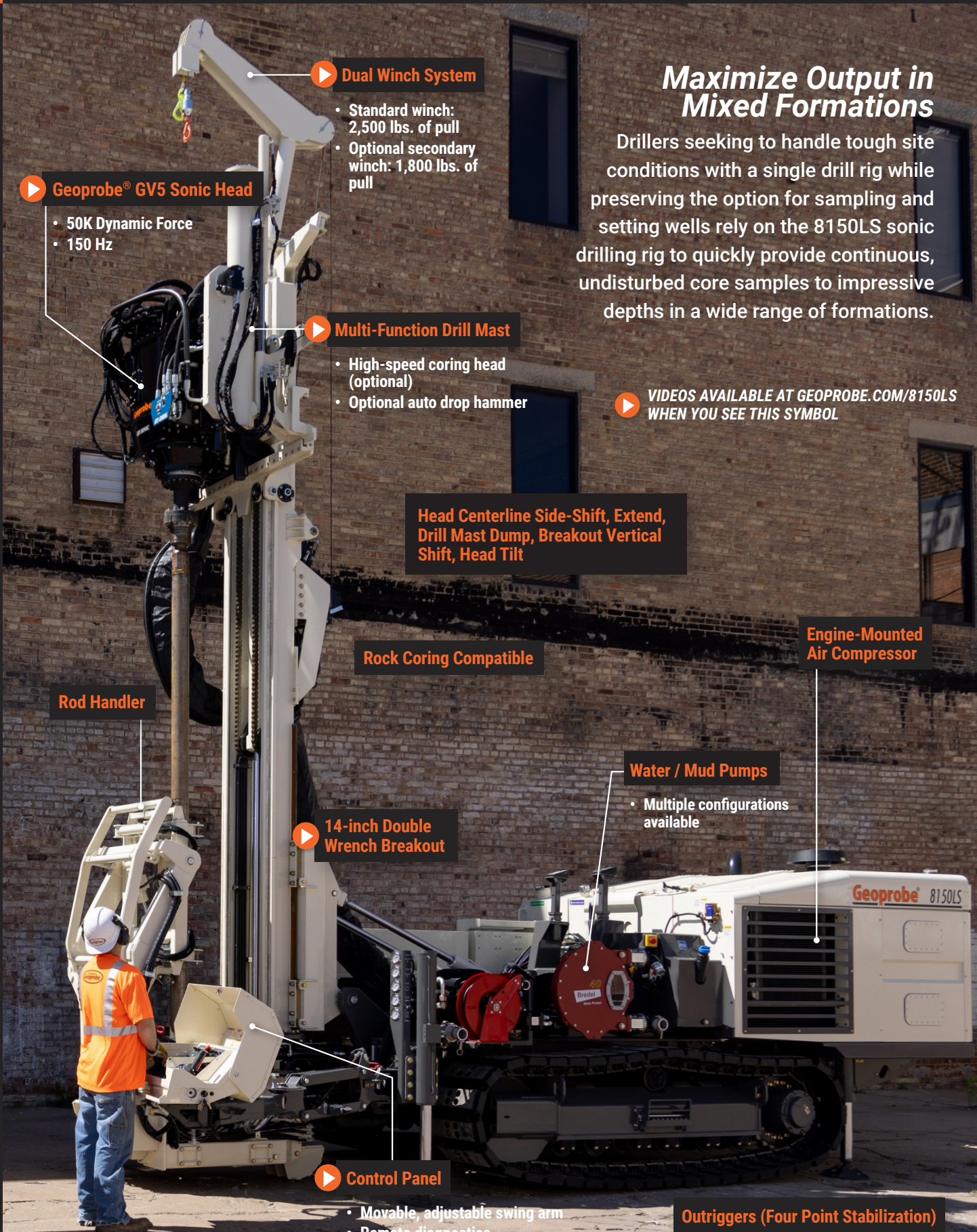

WEIGHT & DIMENSIONS

Base Unit Weight: **32,500 lb. (14,742 kg)**
 With Typical Options*: **33,500 lb. (15,195 kg)**

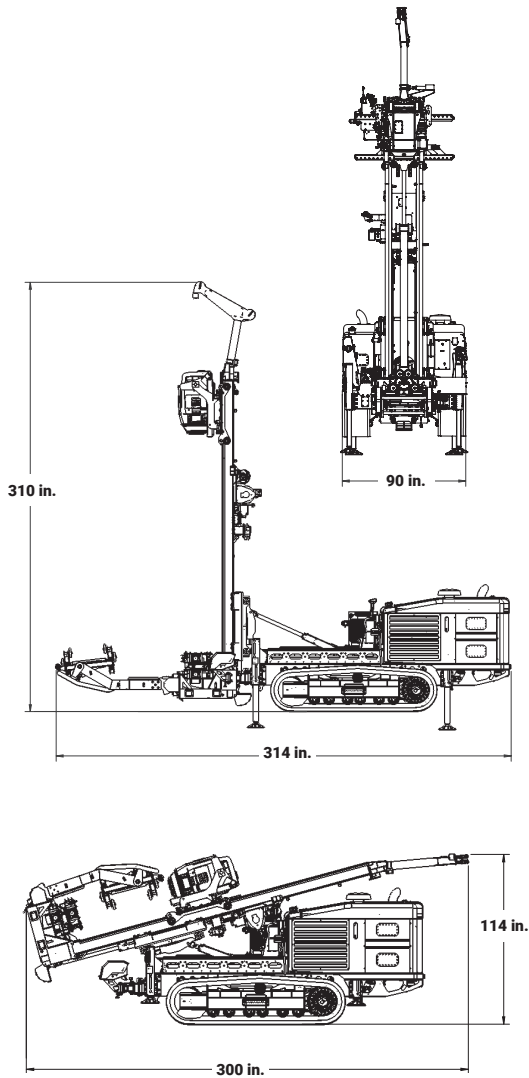

TOOLING

Typical Geoprobe® Tooling for the 8150LS

- Casing Sizes: 10 in., 8 in., 6 in., 4.5 in., 3.5 in. HD
- Weighted Wire Line Sampling (WWL60)
- Dual Tube Sonic Sampling (SDT60)
- 8 x 10, 6 x 8, 4 x 6 HD Sonic Sampling
- SP60 Groundwater Sampling

Rig shown with optional features. Weights & dimensions subject to change without notice.
 *Typical extras and options include hose pump, rod handler, second winch, and 48-in. toolbox. Standard features include triplex pump, breakout, air compressor, and head feed pressure control.



OPTIONS

High-Speed Coring Head Options

- GV5 High Speed Coring Head Drive
- Float Sub (NWJ) Pin Assembly
- Float Sub NWL (NQ) Pin Assembly
- Float Sub NWT Pin Assembly
- Float Sub HWT Pin Assembly
- Float Sub HWL (HQ) Pin Assembly
- 150 gal. Water Tank

Automatic Drop Hammer

- Automatic Drop Hammer Only, 140 lb.
- Drop Hammer Mounting Brackets
- Expansion Kit
 - 340 lb.
 - 300 lb.
 - 170 lb.
- Weight, 65 kg

Spindles

- GV5 Spindle Adapter, 6.0 in. RHSL, 4.5 in. HDR Assembly
- GV5 Spindle Adapter, 6.0 in., 4.5 in., 3.5 in. Assembly
- GV5 Spindle Assembly
- GV5 Matrix Spindle Assembly

Mast & Winch

- Wireline Winch Kit: 1,100 lbf or 1,800 lbf with Quick Change Hook
- Drill Mast Adjustable Brace Kit

Rod Handler

- Rod Handler System
 (3 in. to 9 in., Double Jointed, Integral Safety Features)

Rotational Safety Cage

- Safety Cage
- Head Feed Rod Handler Interface Interlock Kit

Water & Mud Pumps

- SPX40 Hose Pump Kit
- Hose Reel Kit - Kerr Pump Mount
- 9.625 Casing Containment Pan

Toolboxes & Racks

- 48 in. Toolbox
- Indexing Rack, 6.0 in. Casing
- Indexing Rack, 4.5 in. Casing
- Indexing Rack, 7.625 in. Casing
- Sonic Rod Rack 4 x 6
- 4 x 6 Extension Caddy
- Rod Rack with Roller
- Stack Rack

Air Compressor

- Air Line Oiler Kit

See the SC30DT Sonic Rod Carrier for a completely hands-free operation.



GV5 High Speed Coring Head Drive



Wireline Winch Kit



Rod Handler System



SPX40 Hose Pump Kit

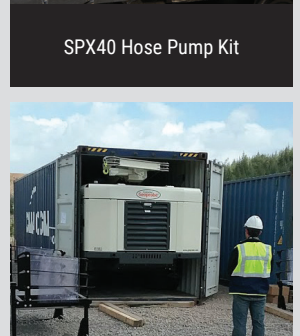

The 8150LS fits inside a 40-foot shipping container.

Videos, Photos, Specifications, Resources
geoprobe.com/8150ls

