

Geoprobe® 3230DT Drill Rig

Direct Push, Geotech, & Rotary Drill Rigs | 3230DT

Get More From One Machine

Drillers who need big pushing power with the versatility to perform air and mud rotary drilling, augering, diamond coring, CPT, and SPT rely on the 3230DT. The 3230DT is the powerful heavyweight machine that gets big jobs done with precision and efficiency.

▶ VIDEOS AVAILABLE AT GEOPROBE.COM/3230DT WHEN YOU SEE THIS SYMBOL

▶ Patented CB Combo Head

- Percussion hammer
- Air rotary, augering, direct push/percussion, diamond coring, mud rotary, and SPT
- 4-speed rotary drive
- Patented hydraulic head clamp
- Torque options up to 6,000 ft-lbf and speeds up to 800 rpm

▶ 26 inches of Head Side Shift

▶ 7-inch Single Clamp Breakout

▶ Telescoping Winch Mast

- Allows for operation at variable heights

▶ Triple Winches

- 8,500 lbf, 5,000 lbf, 1,800 lbf, and 1,100 lbf options available

▶ Drill Mast

- 84 inches of head feed travel
- 50,000 lb. of push force
- 80,000 lb. of pull force
- Extend, swing, mast dump, oscillation, and fold

▶ Automatic Drop Hammer

▶ Water / Mud Pumps

- Multiple configurations available
- Separate hydraulic circuit improves mud rotary performance

▶ Control Panel

- Movable, adjustable swing arm
- Drilling control configurations

▶ Outriggers for Stabilization



WEIGHT & DIMENSIONS

Base Unit Weight: 17,500 lb. (7,938 kg)
With Typical Options: 20,500 lb. (9,299 kg)

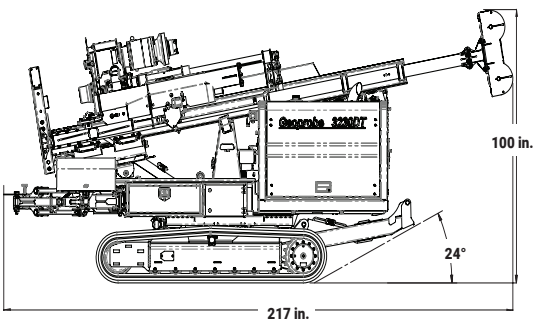
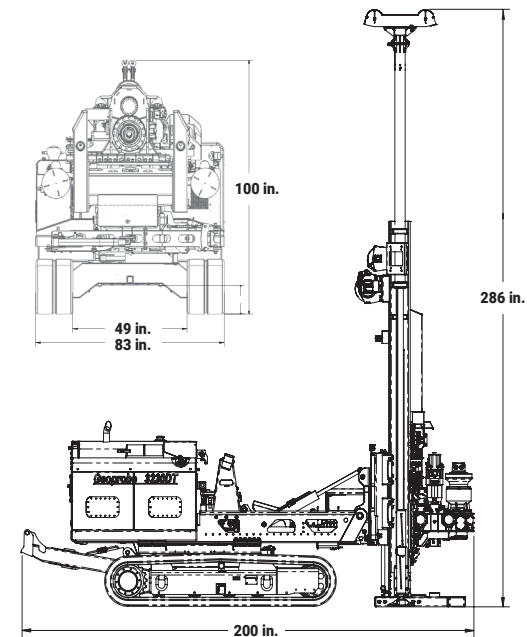

TOOLING

Typical Geoprobe® Tooling for the 3230DT

- 60 in. Direct Push Tooling
- Probe Rod Sizes: 6.0 in., 4.5 in., 3.75 in., 2.25 in.
- Dual Tube Soil Sampling (DT60, DT45, DT37)
- Groundwater Sampling (SP22)
- Prepacked Monitoring Well Installations (up to 2.0 in.)
- HSA System (up to 8.25 in.)
- NWL Wireline System
- SPT Sampling (Interlocking Split Spoon Sampler, Driven Casing SPT, HSA, Solid Auger, Mud Rotary)

Hydraulic head clamp assembly for mobile drill rig manufactured under US Patent 8,056,640
Rig shown with optional features. Weights & dimensions subject to change without notice.



OPTIONS

Combo Head Options

- 2-Speed Combo Head with GH70 Hammer (6,000 ft-lbf, 150 rpm)
- 4-Speed Combo Head with GH70 Hammer (6,000 ft-lbf, 800 rpm)

Combo Head U-Joints

- 1.625 Female Hex U-joint Assembly
- 2.0 Female Hex U-joint Assembly
- Hollow Stem Auger 4.25 HDZK
- Hollow Stem Auger 6.25 HDZK

Automatic Drop Hammer

- Automatic Drop Hammer, 140 lb.
- Expansion Kit
 - 340 lb.
 - 300 lb.
 - 170 lb.
- Weight, 65 kg

Mast & Winch

- Telescoping Mast, Dual Winch
- Telescoping Mast, Triple Winch
- 3 ft. Mast Extension
- Winch Kit: 8,500 lbf (Pos. 1)
- Winch Kit: 5,000 lbf (Pos. 1)
- Winch Kit: 1,800 lbf with Quick Change Hook (Pos. 2)
- Winch Kit: 1,100 lbf with Quick Change Hook (Pos. 2)
- Winch Kit: 1,800 lbf with Quick Change Hook (Pos. 3)
- Winch Kit: 1,100 lbf with Quick Change Hook (Pos. 3)

Breakout

- 9 in. Pullback Breakout Kit
- 7 in. Breakout Kit
- Coring Upgrade Kit for 7 in. Breakout

Rotational Safety Cage

- Safety Cage

Water Swivels

- Water Swivel and Bracket
- Top Spline Water Swivel (4-Speed only)

Control System

- Head Feed Pressure Control Kit

Water & Mud Pumps

- Moyno® 3L8 Pump
- Moyno® 3L6 Pump
- SPX40 Pump
- Triplex Pump
- Centerline 7.5 x 10 Mono Pump

Hydraulic Extruder

- Hydraulic Extruder Kit
- 3 in. Shelby Tube Hydraulic Cradle Assembly

Toolboxes & Rod Racks

- 53 in. Toolbox
- 20 in. Toolbox
- Tool Rack Side Mount

Additional Options

- Aluminum Mud Tub 175 gal.
- Measurement While Drilling (MWD)
- 3230 CPT Anchor Kit
- Air Line Oiler Kit
- Drill Mast Outrigger Kit
- LIM Data Acquisition System

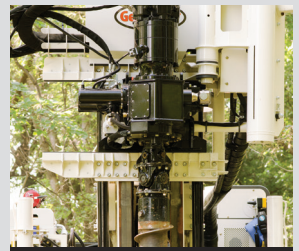

4-Speed Combo Head



Automatic Drop Hammer, 140 lbs.



Telescoping Mast, Dual Winch



Pullback Breakout Kit

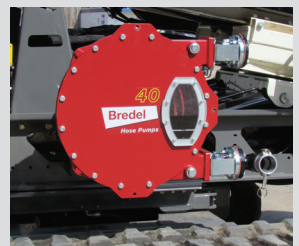

SPX40 Pump Kit

Videos, Photos, Specifications, Resources
geoprobe.com/3230dt

