

Geoprobe® 3100GT Geotech Drill Rig

Geotechnical Sampling – Powerful, Flexible, Fast, Easy on Drillers

The Geoprobe® 3100GT geotechnical rig is designed to quickly perform SPT borings (augers & mud rotary), collect Shelby tube samples, rock cores, and push CPT.

▶ VIDEOS AVAILABLE AT GEOPROBE.COM/3100GT WHEN YOU SEE THIS SYMBOL

▶ Geotech Head Options

(All functions are available along the head side-shift)

- 4-speed rotary head (4,000 ft-lb, 750 rpm) (standard option)
- 6-speed rotary head (6,800 ft-lb, 720 rpm) (high torque - optional)
- GH63 percussion hammer
- CPT push / pull assembly
- DH104 automatic drop hammer (hands-free)
- Rod grip pull system

▶ Hands-Free Automatic Drop Hammer

Mud Pumps

- Multiple configurations available
- Separate hydraulic circuit improves pump performance

▶ Telescoping Winch Mast

- Primary winch
 - 6,800 lbf.
- Secondary winch options
 - 2,500 lbf.
 - 1,800 lbf. (quick change hook)
 - 1,100 lbf. (quick change hook)
- Third winch - optional
 - 1,100 lbf. (quick change hook, wireline)

▶ Drill Mast

- 105 in. of head feed travel
- 36,000 lb. of push force
- 48,000 lb. of pull force
- Extend, swing, mast dump, oscillation, and fold
- Direct push options

No CDL*
Required!
(*Class A/B)

▶ Control Panel

- Manual controls provide tactile feel
- Electric controls add safe, hands-free operation

▶ 28 inches of Head Side Shift

▶ Swing-Out 7-inch Breakout



WEIGHT & DIMENSIONS

Base Unit Weight: 18,500 lb. (8,391 kg)

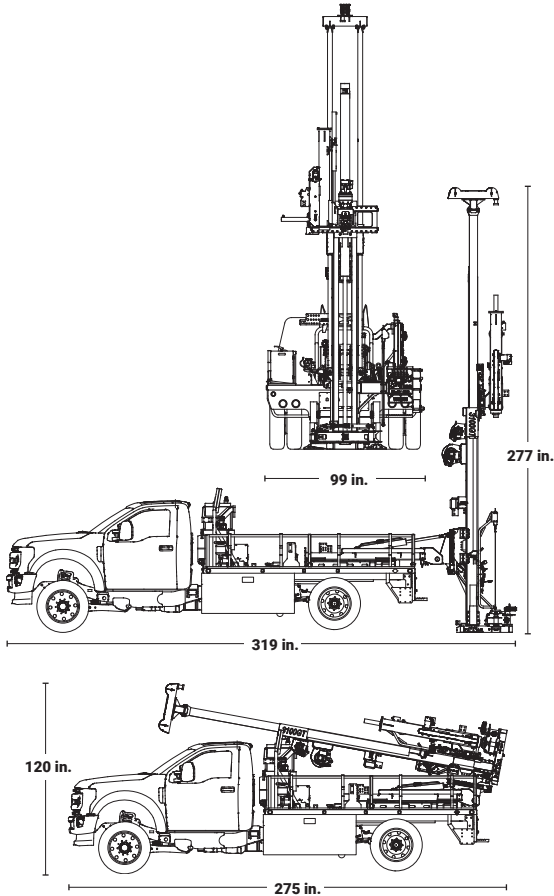

TOOLING

Typical Geoprobe® Tooling for the 3100GT

- **Geotechnical Tooling**
 - SPT Sampling (Interlocking Split Spoon Sampler, Driven Casing SPT, HSA, Solid Auger, Mud Rotary)
 - Cone Penetration Testing (CPT)
- **Direct Push**
 - 60 in. Direct Push Tooling
 - Probe Rod Sizes: 3.75 in., 3.25 in., 2.25 in., 1.5 in., 1.25 in.*
 - Macro Core® Soil Sampling (MC5, MC7)
 - Dual Tube Soil Sampling (DT37, DT325, DT22)
 - Groundwater Sampling (SP22, SP16)
 - Prepacked Monitoring Well Installations (2.0 in., 1.5 in., 1.0 in., 0.75 in.)
 - Direct Image® Tooling
- HSA System (3.25 in., 4.25 in., 6.25 in.)

* Center Rod Use Only

Rig shown with optional features. Weights & dimensions subject to change without notice.



OPTIONS

Head Options

- Geotech Head Assembly (4-Speed Rotary Head)
 - 4,000 ft-lbf
 - 750 rpm
- Geotech Head Assembly (6-Speed Rotary Head)
 - 6,800 ft-lbf
 - 720 rpm
- GH63 Percussion Hammer

Automatic Drop Hammer

- Automatic Drop Hammer, 140 lb.
- Expansion Kit
 - 340 lb.
 - 300 lb.
 - 170 lb.
- Weight, 65 kg

Mast & Winch

- Primary Winch
 - 6,800 lbf
- Secondary Winch (Options)
 - 2,500 lbf
 - 1,800 lbf (quick change hook)
 - 1,100 lbf (quick change hook)
- Third Winch (Optional)
 - 1,100 lbf (quick change hook, wireline)
- Telescoping Dual Winch Mast
- Telescoping Triple Winch Mast
- Mast Extension, 3 ft.
- Drill Mast Outrigger Kit

Breakout

- 7 in. Breakout
- Coring Upgrade Kit for 7 in. Breakout
- Breakout Storage Rack

Rotational Safety Cage

- Safety Cage

Water Swivels

- High Speed Water Swivel with Float
- Float Sub NWJ Pin Assembly
- Float Sub NWL Pin Assembly
- Float Sub HWL Pin Assembly
- Water Swivel Assembly

Control System

- Head Feed Pressure Control Kit

Water & Mud Pumps

- Moyno® 3L6 Pump Kit
- Moyno® 3L8 Pump Kit

Hydraulic Extruder

- Hydraulic Extruder Kit
- 3 in. Shelby Tube Cradle

Toolboxes & Rod Racks

- 10 ft. Tool Rack, Side Mount
- 5 ft. Tool Rack Assembly - Side Mount
- Underbody Toolbox, 60 in. x 17 in. x 18 in.
- Underbody Storage Kit - Driver Side
- Underbody Storage Kit - Passenger Side
- Rear Underbody Storage Package
- 2.0 Split Spoon Table Weldment
- 5 ft. Toolbox on Deck
- 5 ft. Tool Rack w/ 5 ft. Toolbox
- 10 ft. Tool Rack w/ 5 ft. Toolbox

Mud Pans

- Aluminum 100-gal. Mud Pan
- Steel 40-gal. Mud Pan

Additional Options

- CPT Accessory Package
- Yoke Vise & Mounting Bracket Kit, Horizontal
- Rod Grip Pull Latch
- Dropdown Work Table
- Light Kit
- 50 gal. Water Tank w/ Pump
- Measurement While Drilling (MWD)
- LIM Data Acquisition System

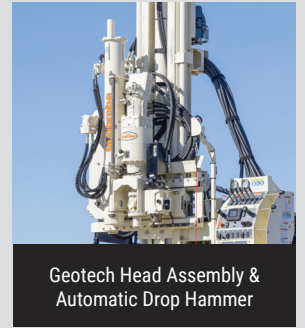

Geotech Head Assembly & Automatic Drop Hammer

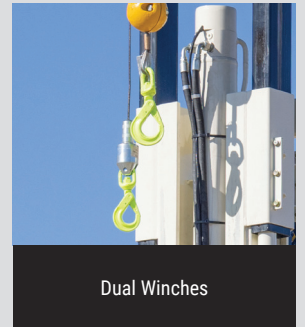

Dual Winches

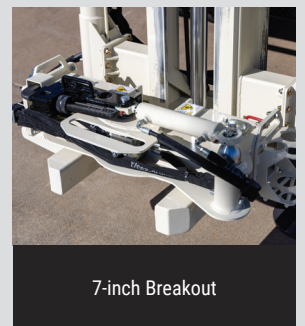

7-inch Breakout

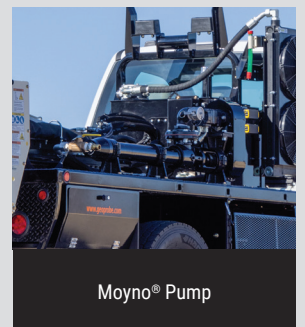

Moyno® Pump

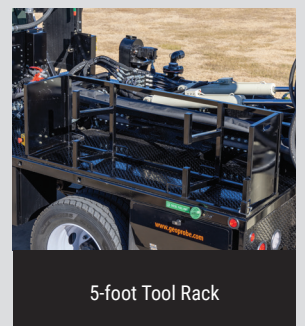

5-foot Tool Rack

Videos, Photos, Specifications, Resources
geoprobe.com/3100gt

