

PROBING TIMES

Information for the ENVIRONMENTAL, GEOTECHNICAL, GEOTHERMAL EXPLORATION, & WATER WELL Industries

3100GT Geotech Rotary Rig



GEOPROBE® RELEASES TWO NEW **GEOTECHNICAL** SAMPLING RIGS



150GT Geotech Rotary Rig





GEOPROBE® RELEASES TWO NEW

3100GT

Geotechnical Rotary Rig (5 ft. Tooling)

Over the last 15 years Geoprobe® has increasingly been supporting customers focused on successful geotechnical investigations. On many geotech sites, the need for speed and efficiency is of the utmost importance. The specific methods of geotechnical sampling varies greatly and are usually dependent on a combination of subsurface site conditions and what is considered an acceptable practice in the geographic region. *The Geoprobe® Engineering Team set out to design a rig specifically for geotechnical sampling that could quickly perform SPT borings (augers and mud rotary), collect shelly tube samples, take rock cores, and push CPT cone...all on a 19,500 lb. GVWR truck that does not require a Class A or B CDL to operate.* From this vision, the all new Geoprobe® 3100GT was born.

For more information:
geoprobe.com/3100gt

HANDS-FREE AUTOMATIC DROP HAMMER

SWING OUT 7 IN. BREAKOUT

TELESCOPING WINCH MAST

- Allows tripping out of 20 ft. lengths of rod when combined with 3 ft. extension
- 7,000 lb. primary winch
- 1,800 lb. secondary winch with Quick Change Hook

DRILL MAST POSITIONING

- Extend, Swing, Mast Dump, Oscillation, and Fold
- Quickly deploy and position drill mast where the hole dictates

DRILL MAST

- 105 in. of head feed travel
- 36,000 lb. of push force
- 48,000 lb. of pull force
- Direct Push Options

MULTIPLE ROTARY HEAD OPTIONS

(Full Torque in Forward and Reverse for all head options)

- GA400 (4,000 ft-lb, 150 rpm)
- GA4100 (4,000 ft-lb, 650 rpm)
- CB5 (6,000 ft-lb, 600 rpm)

26 IN. OF HEAD SIDE-SHIFT

CONTROL PANEL

- Manual controls provide tactile feel
- Electric control adds SAFE, HANDS-FREE operation



GEOTECHNICAL SAMPLING RIGS

No CDL*
Required!
(*Class A/B)

TELESCOPING WINCH MAST

- Allows tripping out of 20 ft. lengths of rod when combined with 3 ft. extension
- 7,000 lb. primary winch
- 1,800 lb. secondary winch with Quick Change Hook

DRILL MAST

- 144 in. of head feed travel and 45 in. of drill mast dump.
(This easily gives you the range you need to work ground level, above a pan or drill at an angle.)
- Drill mast utilizes rollers instead of sliders
- Easily adjust to hole misalignment with extend and swing

CB5 4-SPEED HEAD

- 6,000 ft-lb torque; 600 rpm.
(Torque to spin augers, speed to high speed core)
- 6.25 in. external drive for HSA
- Top swivel with 2.5 in. float and 2 3/8 in. API output.

DH107 AUTOMATIC DROP HAMMER

- On independent feed with 73 in. of travel

SWING OUT 7 IN. BREAKOUT

22 IN. OF HEAD SIDE SHIFT

HIGH CAPACITY HYDRAULICS POWERED OFF TRUCK ENGINE (SAVES WEIGHT AND SPACE)

MULTIPLE MUD PUMP OPTIONS

CONTROL PANEL

- Simple manual controls with operator feedback (weight on bit, rotation RPM, engine diagnostics)

150GT

Geotechnical Rotary Rig (10 ft. Tooling)

Specifically designed for customers focused on traditional geotechnical drilling applications utilizing: hollow stem auger, solid stem auger, SPT, mud rotary, air rotary, and high speed coring...Geoprobe® has released the all new Geoprobe® Model 150GT.

As we spent time with clients focused on rotary geotechnical projects, it became clear that some clients preferred 5 ft. tooling systems while others demanded speed; speed that could only be achieved by operating 10 ft. tooling. There was really no single drillmast configuration that could offer our customers a real solution for every application. **For those customers that utilize 10 ft. tooling systems consistently, we are now able to offer a solution that we believe provides the drilling industry unique features that in the end will help Geoprobe® customers succeed.**

For more information:
geoprobe.com/150gt

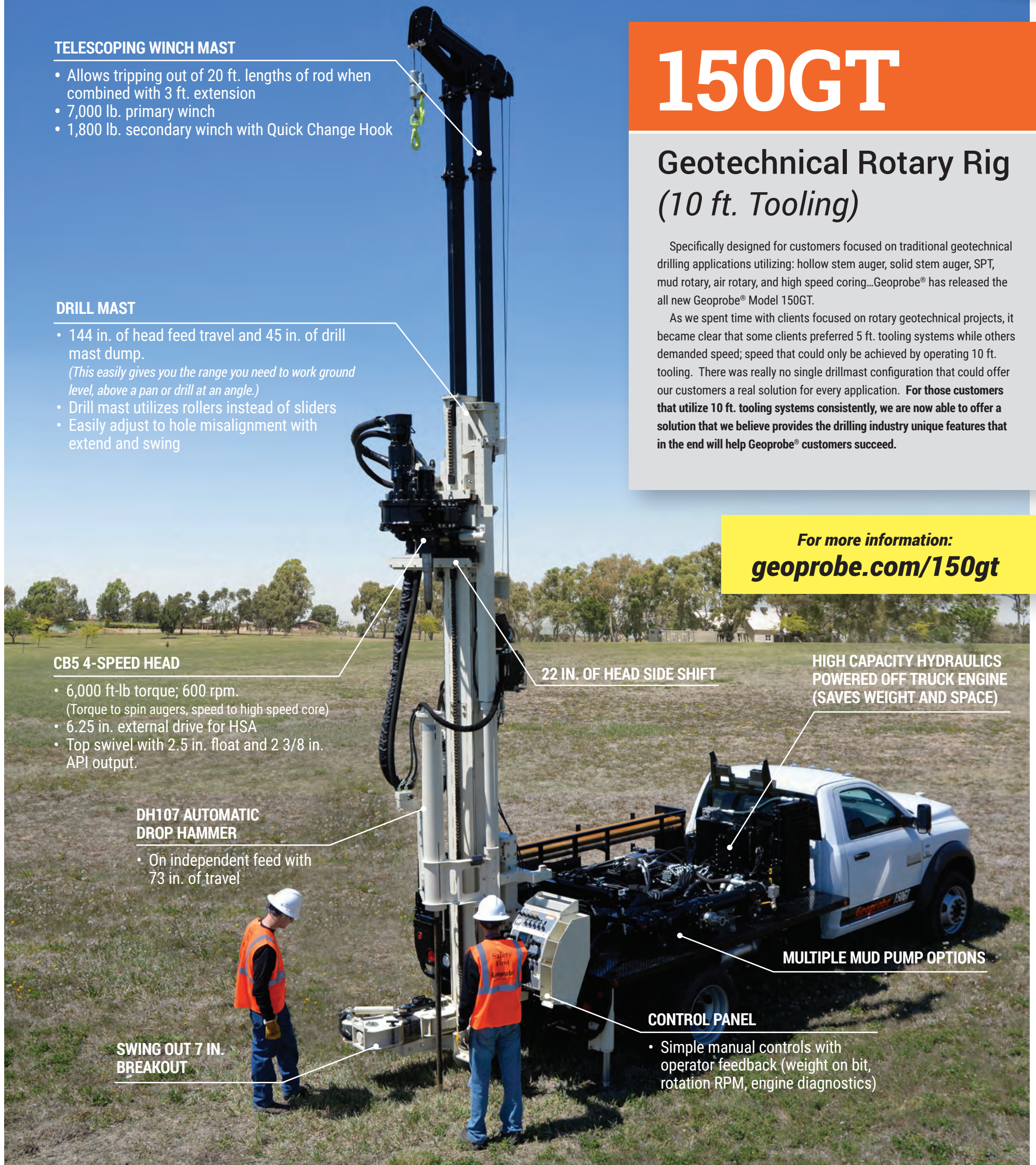

Nebraska DOT: 3230DT is an all-inclusive timesaver

The Nebraska Department of Transportation found exactly what it was looking for with the 3230DT – an all-in-one drill rig for field investigations.

“The 3230DT allows us to switch from mud rotary, rock coring, hollow stem or straight auger, CPT, or direct push easily and with limited time interruptions,” said Mark Lindemann Geotechnical Engineer for the Nebraska Department of Transportation.

The NDOT’s first project with the 3230DT took place in the Nebraska Sandhills – the largest sand dune formation in the Western Hemisphere.

“We needed to get several borings and test data for a proposed sheet pile wall,” Lindemann said. “We were able to take SPT tests through the 4.5 inch direct push casing until we got refusal in the dense sands at about 40 feet. Then, we switched over to mud rotary drilling with the casing in place. It was nice to be able to keep going and not have to start a boring completely over.”

The NDOT splits its geotechnical drilling into three main groups: bridge foundations (deep foundations), soil mechanics (undisturbed sampling for embankments, walls, culverts, and landslides), and soil survey (bulk samples for subgrade, soil suitability, and wetland mitigation).

“One of the things we were looking for was versatility – a one-stop shop machine that could do everything we needed to in our field investigations,” Lindemann said.

It’s been a 10-year journey of research and approvals, but NDOT received the OK in 2016 to make the purchase.

“We’ve been working with Lee Shaw since 2012 and he has been so helpful and patient with us,” Lindemann said. “That is one of the factors that helped us decide which manufacturer to go with – the prompt, knowledgeable and friendly service we have received from Geoprobe® staff.”

NDOT took delivery of its 3230DT in 2017 but was first introduced to Geoprobe® in 2005 when purchasing a wireless Cone Penetration Test (CPT) system. The NDOT utilizes CPT for in-situ testing and is currently performing CPT research with the 3230DT that will enable the department to design deep foundations with additional accuracy when compared to more common SPT methods.

“The anchoring system has been a big benefit to enable us to reach the depths we need,” Lindemann said. **“Another benefit is the ability to dial in the feed rate for improved CPT testing quality and less fatigue for the operator trying to hold a constant feed rate. And finally, the head clamp makes it easier to push CPT rods to greater depths and also pull the rods out of the ground quicker and safer.”**

The group is just getting started, though, when it comes to using the 3230DT to its full potential.

“Our track-mounted 3230DT allows us to get into rugged terrain and soft ground areas we typically couldn’t access before,” Lindemann said. “We also plan on using the direct push 4.5 inch casing to install monitoring wells for wetland mitigation sites and see the direct push method as a big time-saver versus conventional drilling methods.”



Top Right: (l to r) Driller Allen Hilgren and Engineer Alex Silvey perform CPT research for pile design at a bridge over Interstate 80 east of Lincoln, NE, using the 3230DT.

Bottom Right: Driller Doug Churchwell performs CPT research for pile design at a bridge over the Platte River using the Nebraska Department of Transportation’s new Geoprobe® 3230DT.



Left: The Nebraska Department of Transportation performs a forensic investigation in the approach fill at the Platte River Bridge south of Fremont, NE. Direct push sampling with the 3230DT allowed NDOT to immediately review samples to see if frozen soil or ice lenses were present and could have caused the pavement to heave and crack.



CPT Offerings Continue to Grow

2060CPT makes field jobs efficient, comfortable

The Geoprobe® 2060CPT is a 20-ton-rated, static push Cone Penetration Testing platform that allows users to maximize their efforts in a climate-controlled environment.

The cabin crawler is equipped with a proven Geoprobe® 142 HP engine/hydraulic system that provides excellent climbing and turning ability in rugged, unlevel terrain and on steep grades.

The cabin crawler delivers on power with 20 tons of downforce and 30 tons of pull, while emitting low ground pressure at 7 psi for minimal terrain disturbance.

A swinging control panel allows for operation from either side of the low-profile CPT press.

Features include an undercarriage camera, four outriggers, an auxiliary bottom clamp to secure the tool string when the push clamp is released, and optional auto-seis shear wave generators.



Optional 6712 Mast for Geoprobe® 2060CPT: Need an easier way to pre-drill a hole for CPT tooling, direct push sample with the hammer or drill to clear debris? The optional 6712 mast allows you to drill, core or sample! It is located in-line with the CPT press inside the cabin, so it's easy to track the crawler over the drilled hole when the time comes to perform the CPT push.

20 CPT Press NOW AVAILABLE with skid steer configuration

The 20 CPT Press from Geoprobe® is a flexible mast option with a 20-ton push capacity, designed specifically for performing cone penetration tests.

The 20 CPT Press can be ordered with either a skid steer mounting plate or a 6712DT mount. In either case, the 20 CPT Press can be connected to the hydraulic power source in less than 10 minutes.

Being lightweight and compact allows the 20 CPT setup to easily be transported from location to location and do work in difficult access locations.



The Geoprobe® 20 CPT flexible mast option with quick mount design easily attaches to various skid steer loaders (right) or the Geoprobe® 6712DT direct push machine (top).



20 CPT Features Include:

- Synchronized anchoring • Hydraulic rod clamp located directly centered between main push cylinders
- Hydraulic outriggers for leveling • Hydraulic operated lower clamp for holding rods

And all these features are easily controlled at a single control station.

CPT Machines

CPT Tools

CPT Training

CPT Calibration

CPT Parts

Geoprobe® has offered CPT tooling, technology, service, and parts for more than 20 years.

In the last five years, the number of CPT users has grown significantly. As a result, Geoprobe® has expanded our CPT offerings to meet customer demand.

In addition to our lightweight and mobile tracked machines that can be equipped to push CPT, we now offer the 2060CPT: a 20-ton static push CPT platform. The 20 CPT Press, which is a 20-ton flexible mast option, can be easily mounted to our 6712DT direct push machine and various skid steer loaders. It serves as an alternative when access to the site is limited.

We continue to provide both cordless and corded CPT systems than can be deployed with any push platform and are widely recognized for both their reliability and durability. This includes the NOVA CPT system. You just can't afford to overlook this wireless system's capabilities, which provides a constant stream of data to the surface through push rods and needs little to no adjustment when it's time to calibrate.

If you have any questions about CPT machines or tooling, contact us at 785-825-1842.



Troy Schmidt
Geoprobe®
CPT Specialist



WATCH THE VIDEOS:

geoprobe.com/2060CPT
geoprobe.com/CPT-Press



3230DT in Texas: Advances CPT Nicely

I've been operating the 3230DT since its release and the capabilities continue to impress me.

In April, we successfully used the 3230DT geotechnical combo rig to deploy CPT at a chemical plant construction site in Texas.

To be able to mobilize one track machine and then push CPT effectively with a lightweight platform in difficult subsurface conditions was essential to the customer. The 3230DT successfully met each requirement and more.

The advantage to using the 3230DT is that



Lee Shaw
Geoprobe® Sales

you have multiple drilling methods at your fingertips and can easily transition from rotary applications to CPT – all using the same powerful combo head.

Features such as the sideshifting head and rod clamp are an added bonus, allowing operators to sideshift the head without moving the machine, raise the rod with the rod clamp to remove friction, sideshift back and then continue deploying CPT.

My overall experience running CPT with the 3230DT is that it's actually very relaxing and quiet. With the engine at idle and using the head feed rate control, I could precisely adjust the cone advancement to 2 cm/second and maintain that speed.

At some locations we pushed with just the static weight of the 3230DT, which gave us approximately 5 tons of downforce. For the deeper CPT locations we installed anchors to tie down the 3230DT drill mast before pushing the CPT cone. The anchors held and allowed us to perform the maximum 20 tons of downforce push. Impressive.

We have several customers who perform CPT and seismic CPT with the 3230DT because it has the ability to efficiently sample the subsurface using both direct push and rotary drilling techniques and then quickly transition to pushing the CPT cone.



The Geoprobe® 7822DT pictured above is equipped with the CPT control module.

3230DT's 80,000 lb. of pull back gives Shepler Well Drilling peace of mind



Shepler Well Drilling, Inc., completes split spoon sampling in Traverse City, MI, as part of a geotechnical site investigation for a new parking deck using their Geoprobe® 3230DT. The torque and pull back on the 3230DT put the crew at ease knowing they can retrieve their augers no matter what depth they reach on projects. Pictured are Operators Cole Shepler and Clint Bridson with Shepler Well Drilling.

Shepler Well Drilling, Inc., of Manton, MI, was in the market for an auger rig when they set their sights on the 3230DT.

"When Geoprobe® told me they could give me 8,500 lb. of torque with 80,000 lb. of pull back, I knew the 3230DT would be the right machine for us," President Randy Shepler said. **"The coring and probing capabilities are just a bonus. When we are doing deep auger jobs, the 80,000 lb. of pull back provides peace of mind knowing you will be getting your augers back out of the hole."**

The 3230DT has also made mobilization easier.

"We can show up on a job site with one machine and have the capabilities to do everything needed – probing, auger, drill, coring, and rotary with the 3230DT."

It's even opened up opportunities for new types of work.

"With the 3230DT we were able to complete a job that required us to have no soil cuttings to be dis-

posed of," Shepler said. **"We set the 2 in. wells with the 4.5 in. rods, gravel packed and grouted in place, and didn't produce any soil cuttings. Before, we would not have been able to even bid the job."**

The Shepler team enjoys testing the power and performance of the machine with each new project, too.

On a recent environmental project in Johannesburg, MI, the team drilled with 4.25 in. augers to 185 ft. with split spoon soil sampling every 10 ft., dry sand and gravel to 175 ft., and set a 2 in. well at 185 ft. At the second site they drilled with 4.25 in. augers, hit water sand at 6 ft., drilled to 195 ft. and set a 2 in. well.

They also completed a geotechnical project in Traverse City, MI, for a new parking deck to be built.

"This machine makes completing the job so much easier tripping the AW rods in and out of the auger / 3-70 ft. and 6-35 ft. water at 15 ft. with 4.25 in. auger with split spoon sampling every 5 ft.," Shepler said.



Shepler Well Drilling, Inc., completes split spoon sampling every 5 ft. in Traverse City, MI, as part of a geotechnical site investigation. Notice the customer built drop rack that utilizes the 3230DT rear blade to mobilize tools and supplies. The rack includes a power washer.



The Shepler Well Drilling crew, which includes Operators Cole Shepler, Darrin Mosher and Clint Bridson, use 4.25 in. hollow stem augers to 195 ft.



Shepler Well Drilling, Inc., President Randy Shepler and Operator Clint Bridson, advance 4.5 in. rods utilizing the GH70 percussion hammer to install wells.

7822DT V3 goes into production

The POWER to WEIGHT ratio of the 7822DT machines is amazing!

When the Geoprobe® Engineering Team released the first 7822DT product in the spring of 2009, we had a good feeling. We knew many features were designed into the compact-sized track machine. Fast forward nine years – looking back we had no clue. We didn't comprehend the impact the 7822DT product would make on the environment and geotechnical industries. The power and versatility of the 7822DT offering allowed Geoprobe® customers to exceed their subsurface sampling expectations and grow their businesses in both direct push and rotary applications. As customers from around the world continue to push 7822DT machines to their limits – tackling difficult site conditions and expanding their subsurface scopes of work – our customers are asking... "How can we do just a little more with our Geoprobe® 7822DT machines?" In response, the Geoprobe® Engineering Team is releasing the Geoprobe® 7822DT V3.

"I like the additional stability when unfolding and extending the drill mast on unlevel ground."
Lee Shaw – Geoprobe® Sales



The Geoprobe® 7822DT V3 is easy to mobilize on unlevel terrain. The oscillation feature allows the rig to be on a slope at an angle while the drill mast is vertical.



NO CDL REQUIRED: Loading and transporting a 7822DT is easy using this F650 transport truck with EZ12 bed.

Mobilizing the 7822DT is simple using the wireless remote. Transporting your tooling is made even simpler with the rear blade for transporting the drop rack tool carrier.



WATCH THE VIDEO:
geoprobe.com/7822DT

Enhanced Hydraulic Cooling

Load sense hydraulics of the V3 machines supply only the system pressure required to perform requested tasks. Under light or no load conditions, system pressure is lowered, significantly reducing heating of the hydraulic fluid. This feature is especially helpful when operating in elevated ambient temperatures and performing high duty cycle operations such as coring, augering, or tracking long distances.

Decreased Fuel Consumption

The V3 operational controls allow the hydraulic system load on the engine to vary depending on the need of the requested task. For many operations, engine load is reduced and therefore less fuel is consumed as compared to systems that maintain high operating pressures for every task regardless of need.

Similar Unit Size and Weight

Strategic engineering design and testing resulted in the 7822DT V3 machine that delivers increased stability, enhanced hydraulic system cooling, and decreased fuel consumption in a package of similar size and weight as previous V2 machines. As commonly equipped, V2 and V3 machines are the same width, height, and similar weight.

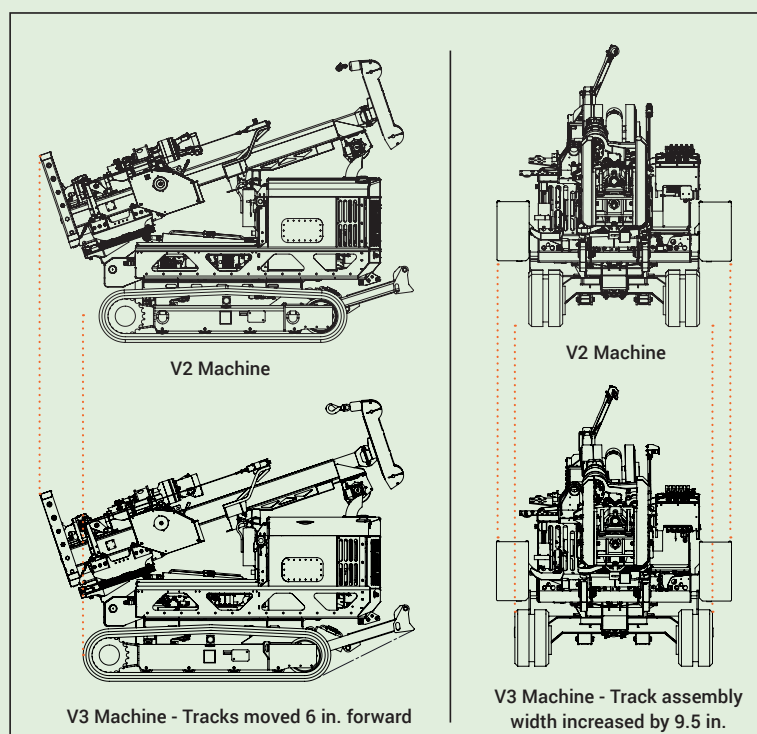

Increased Stability

More than ever, customers are taking the 7822DT to sites that include difficult terrain. The proven track undercarriage has been widened 9.5 inches. Increased track width improves stability on sideslopes, especially when hauling tools in optional side racks. The track system has also been moved forward 6 inches in relation to the powertrain and drill mast. Why? Over the last few years we've seen an increase in customers who are 'loading the drillmast' with optional features for rotary applications (i.e. 4 speed coring head, dual winches, breakout, etc). These features add weight to the drillmast portion of the rig. By moving the tracks forward making it easier for users to operate on job sites safely.



Geoprobe® 8150LS Makes Deep Wells a Breeze for GFA International

The 8150LS sonic drill rig quickly proved itself to GFA International, Inc., while drilling in complex conditions.

“By adding the Geoprobe® 8150LS sonic rig to our fleet, GFA offers our clients a complete range of preferred drilling and sampling methods,” said Tom Ortner, GFA’s Executive Vice President. **“We are now able to offer our clients faster drilling rates and better samples at greater depths and in a wider variety of geological conditions than ever before.”**

GFA International, Inc., is a Florida based Engineering and Geological consulting organization that provides Environmental, Geotechnical, Construction Materials Testing and Inspections services.

GFA was recently retained by AECOM to perform a round of deep wells at the Miami Beach Marina and South Pointe Marina in Miami Beach, FL.

One very important stipulation governing the project was that the Miami Beach Marina site needed to be completed in one week.

This included one 2 in. monitoring well installed to depths of 40-ft. below ground surface, one 2 in. monitoring well installed to a depth of 100 ft. below ground surface, and one 2 in. monitoring well installed to a depth of 250 ft. below ground surface and back plugged to 190 ft. with 10 in. screen.

Gamma logging of the 250 ft. well also had to be performed.

Thanks to the addition of the 8150LS, GFA was able to complete the job on time.

The South Pointe Marina followed with one 2 in. monitoring well installed to depths of 40 ft. below ground surface and one 2 in. monitoring well installed to a depth of 190 ft. below ground surface.

GFA completed these wells in just three days using the Geoprobe® Sonic Weighted Wireline technique.

In addition, GFA was selected by the City of Hollywood, FL, to install four deep salinity observation monitoring wells to 220 ft. in depth in various locations throughout the city.

The 2 in. wells will be used for monitoring of salt water intrusion along the coast of Florida and aid the USGS and city managers in managing the delicate water resources of the City of Hollywood.

In order to meet the timelines and provide near continuous soil sampling for the project, a geologist-approved rotary sonic drilling technique was selected.

Project specifications required discriminate interval water sampling of the boring to determine the conductivity and water quality to design the screen interval of the well.

To accomplish this, GFA used an inflatable packer system designed specifically for the sonic tooling to seal off the water column and pull water samples from specific depth intervals as required by the project geologist.



Lead Driller Brian McCord and Driller John Holdsworth use the 8150LS to install four deep salinity observation monitoring wells to a depth of 220 ft. in various locations throughout the City of Hollywood, FL. GFA International was retained by the City of Hollywood after using the 8150LS to complete a similar project in less than one week.



GFA International uses their 8150LS rotary sonic at the Herbert Hoover Dike, which is part of a rehabilitation project they’ve been working on since 2008.



Driller John Holdsworth, Drill Helper Josh Perell, and Lead Driller Brian McCord set 2 in. wells to 220 ft. The 2 in. wells will be used for monitoring of salt water intrusion along the coast of Florida and aid the USGS and city managers in managing the water resources of the City of Hollywood, FL.

Sonic Training at Turkey Gold Mine with 8150LS



Top and Bottom: Geoprobe® Engineer Joel Christy leads sonic training for the drill crew at the Kisladag Gold Mine in Turkey. The training used 6x8 in. coring through crushed rock of a heap leach pad using Geoprobe® 4.5 in. Heavy Duty (HD) rods as the working rod to drive the 6 in. barrel.



Contributed by Tom Christy, P.E., Vice President of Geoprobe® Systems.

Geoprobe Systems® recently completed commissioning and training on an 8150LS Rotary Sonic Machine at the Kisladag Gold Mine in Turkey.

The Kisladag mine has a variety of drilling projects to carry out with the 8150LS. The photos shown here were taken during training using 6x8 in. coring through crushed rock of a heap leach pad. 6x8 in. coring uses a 6 in. (150 mm) core barrel and 8 in. (200 mm) overcasing. Our training holes ranged from 30 to 40 meters in depth.



Geoprobe® Engineer Joel Christy directs extrusion of a 6 in. (150mm) x 3m core sample while Ramazan Ozkurt of Tuprag Metal Madencilik operates the controls of the 8150LS sonic drill. This core hole is being made through run-of-mine rock.



Tom Christy, P.E., VP Geoprobe® Systems

We found the Kisladag mine to be an organized, well equipped, and efficient operation. Our training crew was very attentive and ready to learn sonic coring. Many of the trainees were already well versed in diamond coring techniques, which was a definite plus. The language barrier of course adds considerable time to any technical training. The trainees all knew more words in English than we knew in Turkish.

The 8150LS machine and tooling are a good fit for this site. **The 8150LS machine with GV5 sonic head had no problems advancing the core barrel through this ground. We used the new Geoprobe® 4.5 in. Heavy Duty (HD) rods as the working rod to drive the 6 in. core barrel. The 4.5 in. HD rods worked very well in this application. The heavy thread sections show good life in the constant make-up and break-out cycling on this site.**

The Geoprobe® Indexing Racks were an absolute necessity on this site. **Using the indexing racks and rod loader, we were able to trip 30 meters of 4.5 in. rods from the hole in less than 10 minutes.** That would be nearly impossible if you are loading rods by hand as well as being a safety issue. The indexing racks allow the drill site helpers to simply roll the rods from loader to rack. The Kisladag drill crew was very pleased with the ease of rod handling with this system.



The Kisladag drill crew use two Geoprobe® Indexing Racks to position Geoprobe® 4.5 in. Heavy Duty (HD) sonic rods into the grippers of the rig-based rod handler on the 8150LS. Using the indexing racks and rod handler, the crew was able to trip 30 meters of 4.5 in. HD rods from the hole in less than 10 minutes.



Geoprobe® Engineer Joel Christy unloads the 8150LS in Turkey. The Geoprobe® 8150LS easily ships worldwide because it fits fully assembled in a 40 ft. shipping container.

Geoprobe® SONIC

Machines • Tools Training • Service Support



Open House Geoprobe

April 26, 2018 • Salina, Kansas



Our fifth Geoprobe® Open House is in the record books and we couldn't have asked for a better day full of sunshine and excitement.

The NEW 3100GT, 150GT, DRILLMAX® 250, 7822DT V3, hands free sonic rod loader, and an array of NEW tools and other machines were on display to showcase our geotechnical, environmental, rotary sonic and water well rig offerings.

With more than 250 guests from 33 states and eight different countries, it is our most well-attended Open House so far. One of our first feedback emails stated:

"Thank you for letting us come to your Open House today. We wanted you to know how impressed we were with the event. Your demonstrations were very powerful and interesting. You have quite a team working together to make some top-notch products. You should be very proud. Thanks again for your hospitality!"

Guests also enjoyed Direct Image® and Service Workshops, and a Customer Appreciation Dinner the day prior to the Open House. We are honored to have welcomed so many customers and guests to our facility in Salina, Kansas.

Please call us at 785-825-1842 or visit geoprobe.com/oh18 to find out more about the new machines and tools demonstrated at Geoprobe® Open House 2018.

Find out more about the NEW products seen at Open House: geoprobe.com/oh18



DRILLMAX® DM250 Water Well Rig Makes Debut

No CDL*
Required!
(*Class A/B)



The DRILLMAX® DM250 is easy to mobilize. The Dodge 5500 chassis (pictured) is equipped with Cummins diesel engine, automatic transmission and 4x4. The compact transport size makes the DM250 a good fit for residential work where limited access is a priority.

DRILLMAX® has been a well-known and respected manufacturer of geothermal and water well rigs for nearly 34 years, based in Ocala, Florida. The company's success has been directly tied to their quality of work and the many relationships forged over the years. DRILLMAX® offers the drilling industry a diverse line up of top head drive drilling rigs.



Tom Omli
Geoprobe®
Sales & Marketing/
Director



Donnie Wood
DRILLMAX®
General Manager

For many years DRILLMAX® and Geoprobe® attended many of the same tradeshows, shares

Tom Omli. "I always looked forward to meeting with Donnie Wood, General Manager of DRILLMAX®, and catching up on the latest news. The more we spoke about the opportunities and challenges our individual companies faced, the more we realized that working together we could help both companies take better care of our respective customer base. In 2017, DRILLMAX® joined Geoprobe®. Bringing companies together is real work, but we are already starting to see new positives emerge."

One positive example is the NEW DRILLMAX® DM250, which was shown publicly for the first time April 26, 2018, at the Geoprobe® Open House in Salina, Kansas. DRILLMAX® has been making DM250 rigs for many years. The DM250 has a proven reputation and is known for being a high production rotary rig that can handle 20 foot drill pipe and still maintain a compact size for mounting on a non-CDL truck chassis. "The combination of torque, mast speed, pumps, and rod loader make drilling 2 in. to 6 in. shallow wells fast and easy on the driller," says Donnie. In addition, the non-CDL chassis makes mobilization to the job sites easier, less costly, and the rig can fit in tight drilling locations.

The simple goals for the NEW DM250 product were to enhance current operator features, simplify manufacturing, improve serviceability, and reduce rig weight.



The DRILLMAX® DM250 is easy to operate with a two-man crew. The helper loads the drill pipe in the single rod loader using helper side controls to operate the jib and winch functions.



Multiple mud and air compressor options include: 3L8, 5x5 duplex, centrifugal pumps, 85cfm development air compressor.



Three spool helper side controls and two E-stop kill switches were added to the DM250.



The DM250 table assembly has clearance for 12 in. pvc casing and the holding fork and hydraulically operated adjustable breakout wrench make tripping out fast and safe.



The neatly laid out DM250 control panel with engine gauge, E-stop, hydraulic pressure gauges, friction control levers for mud pump and rotation circuits, and electronic throttle controls make the DM250 simple and safe to operate.



The DM250 tophead carriage uses rollers instead of slides providing smoother travel, easier maintenance, and longer life.

Learn about our other rigs: www.drillmaxrigs.com

Damasco Penna values reliability, versatility



From left, Test Operator Jucelio Alencar and Drill Rig Operator Dorgival Sales perform a geotechnical site investigation near Poços de Caldas, a city known for its therapeutic hot springs and spas. Using their Geoprobe® 6625CPT and 7822DT machines, the Damasco Penna team sampled through soft clays up to 30 meters, collected rock samples, and performed everything from CPTU to mechanical SPT soundings.



An aerial view of a geotechnical site investigation near Poços de Caldas, Brazil.

Limited-access rigs allow Brazilian company to offer multiple services

Damasco Penna, a geotechnical engineering company based in São Paulo, Brazil, have been expanding their Geoprobe® fleet since 2008.

“The versatility of our Geoprobe® equipment has opened up possibilities to perform diverse kinds of sampling, coring and other site investigation tests,” said Marcelo Penna, Civil Engineer and Manager of Quality. “Our contractors also feel confident when they see our equipment since other companies in our country use improvised rigs to perform similar tests.”

Damasco Penna provides foundations and earthworks consultancy, geotechnical and geo-environmental site investigations, geotechnical instrumentation and soil laboratory tests.

Their Geoprobe® fleet includes two 6625CPTs and two 7822DTs.

“Due to their versatility, we can work with small teams doing a large scope of site investigations,” Penna said. “We are able to perform rock coring, static penetration tests (SPT), soil sampling, concrete coring and other services all with one or two rigs.”

One such investigation included a site near Poços de Caldas, a city known for its therapeutic hot springs and spas.

“We were hired to complete a geotechnical report,” Penna said. “We performed CPTU, DMT, Shelby Samples and Mechanical SPT soundings. We used our 6625CPT and 7822DT rigs in boreholes to 30 meters and also collected rock samples. Usually, our 6625CPT does the static penetration tests while the 7822DT does the soundings and rock coring as well as soil sampling with Shelby samples.”

Damasco Penna has also been busy evaluating tailing dams for mining companies in Minas Gerais, a large inland state in southeastern Brazil. In 2015, an iron ore tailings dam in Bento Rodrigues failed, triggering an uptick in site investigations throughout the area.

“We performed CPTU, DMT and SDMT (Seismic DMT Tests), Vane Tests, as well as Shelby sampling reaching depths of more than 40 meters,” Penna said.

Their Geoprobe® fleet also easily meets Health and Safety codes, since they can be operated by remote control, have moving parts protections and other safety features.

“Our company is really proud of using Geoprobe® equipment,” Penna said. **“They are very reliable and easy to operate. Some of our rigs are already 10 years old and working smoothly.”**



From left, Drill Rig Operator Dorgival Sales and Test Operator Jucelio Alencar perform CPTU tests using the Geoprobe® 6625CPT.

NO CDL REQUIRED: Saves Customers Money & Hassle

Geoprobe® continues to engineer machine configurations that allow drilling companies to mobilize to and from projects without the use of a CDL (commercial driver's license).

Tom Omli shares, "In the past many customers mobilized to job-sites using a heavy duty pick-up truck and construction trailer with no DOT concerns. Now this same configuration is commonly being pulled over by law enforcement and drivers are expected to have a

Class A CDL documentation."

As one customer recently shared, "Developing quality drillers and driller helpers is one thing, but expecting to build up a team of drillers that also have CDL licenses is even more difficult and at times feels nearly impossible."

At Geoprobe® we realize there is a wide range of DOT enforcement that our customers encounter. In some regions customers

appear to have flexibility in their choice of mobilization equipment, while in other states and counties DOT enforcement is very stringent.

Our goal is simple: Provide our customers powerful machines that are compact in overall size and weight. For many customers, the compact rig size gives our customer a substantial economic advantage as compared to mobilizing a large, traditional drilling rig.

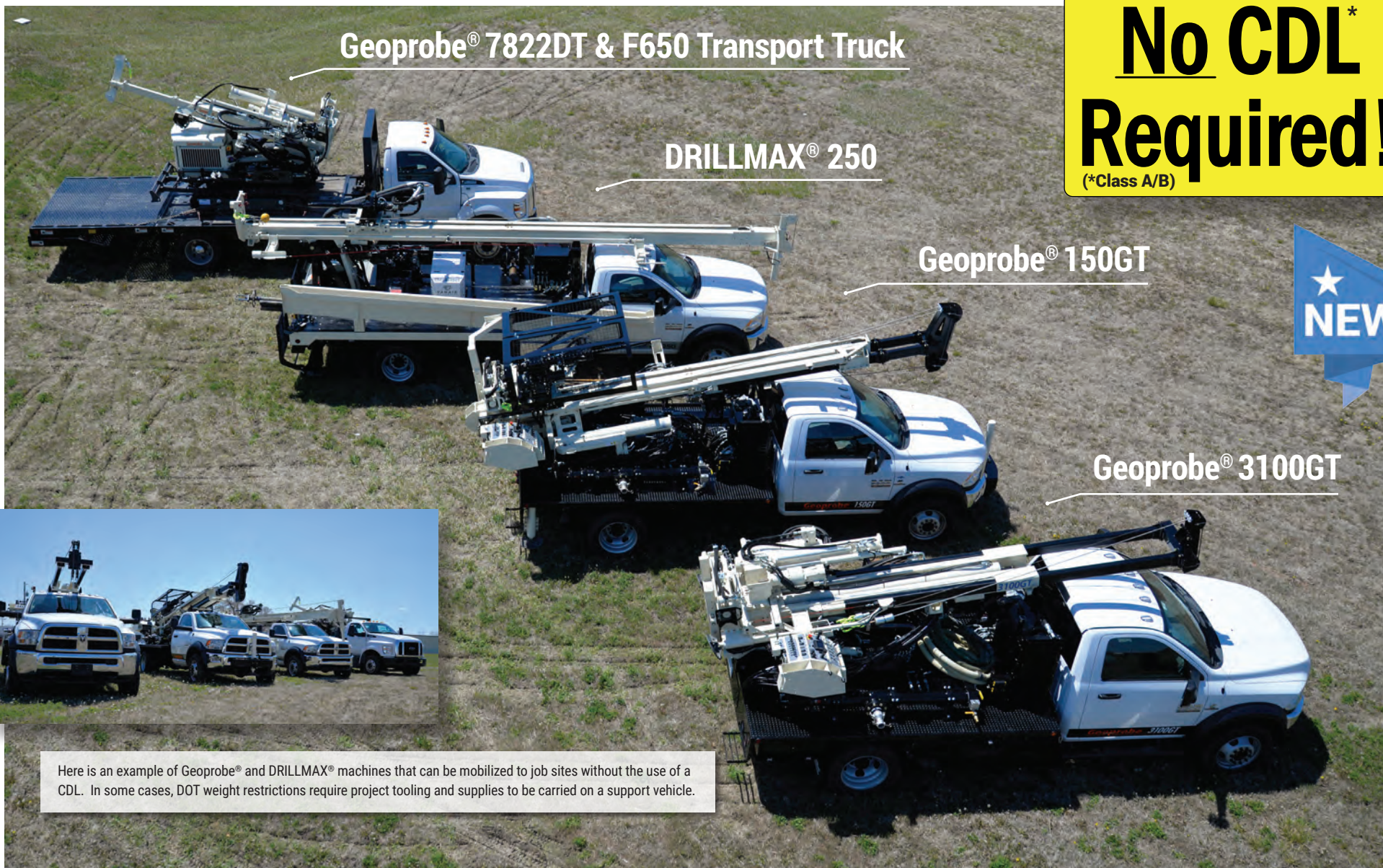

No CDL*
Required!
(*Class A/B)

NEW



Here is an example of Geoprobe® and DRILLMAX® machines that can be mobilized to job sites without the use of a CDL. In some cases, DOT weight restrictions require project tooling and supplies to be carried on a support vehicle.



DT22 Detent Drive Head Makes Soil Sampling Faster & Easier!

Geoprobe® has developed an all new drive head for the DT22 Soil Sampling System – making an already efficient system even faster and easier.

A simple push of a detent pin in the side of the drive head followed by an easy slip fit into the liner is all that's necessary.

The spring-loaded detent pin secures the drive head to the liner, which eliminates the need for a machine vice, set screws, and the "push, wiggle, and wedge" method.

No longer do you have to walk around the rig to the machine vice after every soil sampling interval to replace the used liner with a new liner.

Now, the liner drive head doesn't even have to leave the center rod tool string, nor does the driller or helper have to walk over to the vice to remove the used liner and install a new one. This can all be done right at the borehole at the front of the rig.

Eliminates Hammering • Increases Efficiency • No Tools or Vice Necessary



STEP 1: Push detent pin in with thumb and slide drive head into liner.

STEP 2: The Geoprobe® drive head with spring-loaded detent pin easily snaps into place, securing the drive head to the liner. No need to worry about looking for dropped set screws any longer!



WATCH THE VIDEO:
geoprobe.com/drive-head



VIMS uses 66DT to peer into the past, plan for the future

The Virginia Institute of Marine Science (VIMS) uses their 66DT to dig up the past – literally – along Virginia’s Eastern Shore barrier islands.

“The power of the Geoprobe® 66DT not only allows us to core deeper (we consistently are collecting 60 ft. to 80 ft. cores) but the sturdy track undercarriage also allows us to easily mobilize and work on the beaches and dunes themselves,” said Coastal

Geologist Christopher Hein. “As a result, we have been able to collect the deepest geologic samples ever collected on Virginia’s barrier islands, greatly expanding our knowledge of these islands, and more generally, how stable beaches are in the face of sea-level rise.”

VIMS, in partnership with Randolph-Macon College and the University of Delaware at Newark, are studying the Holocene

geology (last 11,000 years) of the barrier islands. This includes Wallops Island where the NASA Wallops Flight Facility and Virginia’s Mid-Atlantic Regional Spaceport are located. The goal is to better understand why the islands are situated where they are, how they have formed and changed over time, and how stable/resilient they are to sea-level rise.



The Geoprobe® 66DT is easily transported by boat to a remote barrier island.

Geoprobe® 4.5 in. Heavy Duty Sonic Rods are Stronger, Last Longer



The drill crew at the Kisladag Gold Mine in Turkey operate the Geoprobe® 8150LS Sonic rig and Geoprobe® 4.5 Heavy Duty (HD) sonic drill rods.

The Geoprobe® 4.5 in. heavy duty (HD) sonic drill rods are significantly stronger than their traditional counterpart and manufactured at our facility in Salina, KS.

“As we worked with a growing number of clients utilizing the power of the Geoprobe® 8150LS GV5 sonic head to go deeper through more difficult subsurface formations, our engineering team recognized an opportunity,” Engineer Jed Davis said.

The Geoprobe® 4.5 in. HD sonic drill rods are engineered to withstand continuous use in harsh conditions and complement the 8150LS full-size sonic rig with 50K dynamic force, which was designed to continuously sample and set casing in excess of 300 ft. in a wide range of formations.

The Geoprobe® 4.5 in. HD tooling consists of two pieces – the sonic drill rod and the coupler.

“The two-piece design allows you a lot of versatility,” Jed said. “Sometimes you need to pin up or pin down and with this you can piece and part stuff together.”

Its unique design incorporates break out flats into the coupler to minimize wear on the jaw pads when breaking tool joints apart. The two-piece design also saves tooling costs, allowing just the coupler to be replaced if the threads are damaged.

The rounded pin joint speeds up the stabbing of joints together for a faster connection. The tool joint also has a larger cross section, which helps strengthen the drill rod and maximize overall thread life.



Jed Davis
Geoprobe® Tools Group



The drill crew at the Kisladag Gold Mine in Turkey utilize two Geoprobe® Indexing Racks to position the Geoprobe® 4.5 in. Heavy Duty (HD) sonic rods into the grippers of the rig-based rod handler on the 8150LS rotary sonic machine. Pictured are the 4.5 in. HD sonic rods and indexing racks at the gold mine in Turkey.

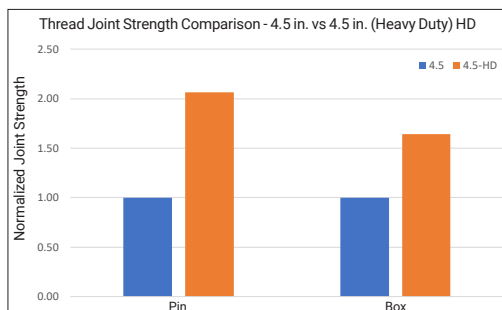

The thread joint strength of the Geoprobe® 4.5 in. Heavy Duty (HD) sonic rod at the pin is 2X stronger while the threads on the other end of the rod are more than 1.5X stronger compared to traditional sonic casing.



“The new Geoprobe® Heavy Duty (HD) sonic tooling line is ahead of the curve. We put in a ton of hours and footage, so going 300 ft. plus puts a lot of stress on the tooling in general. The two-piece interchangeable design is stronger, so you’re getting a longer lasting rod without any downtime. You can use the Geoprobe® HD sonic tooling on projects where the standard rod will give up because it’s too much stress. For instance, the hole can shift off to one side with the Geoprobe® HD sonic tooling, but in that same situation I could easily have snapped standard tooling. The design also makes them break apart easier, which in turn makes your jaw pads last longer. Long-term, it’s a money saving benefit.”

Andrew Gloege • Operator
Geologic Exploration • Statesville, NC



Geoprobe® 4.5 in. Heavy Duty (HD) sonic drill rod (front) and traditional sonic drill rod (back).

MiHpt equips Parratt-Wolff with precise, real-time logging results

Improved site model saves clients time, money



Parratt-Wolff Inc., based in Syracuse, New York, use their Geoprobe® 6712DT in conjunction with Direct Image® tooling to provide their clients high resolution subsurface data and real time logging, which effectively reduces the duration of site remediation for their clients. From left, Project Manager and DI Team Leader Danylo Kulczycky and MiHpt Operator Matt Padgett.

Parratt-Wolff effectively reduced the duration of site remediation for their clients when they introduced MiHpt into their service offerings three years ago.

“With the Direct Image® tools, we can paint a high resolution subsurface picture during the initial site investigation or fill in data gaps that traditional sampling methods have left behind,” said Danylo Kulczycky, Project Manager and DI Team Leader at Parratt-Wolff Inc., based in Syracuse, New York. **“These tools provide the operator and client with real time logging, which allows for more efficient decision-making resulting in one mobilization for site investigation rather than multiple.”**

The MiHpt, which combines the Membrane Interface Probe (MIP) and Hydraulic Profiling Tool (HPT), is ideal for determining contaminant mobility and migration pathways – and it’s been a game-changer for Parratt-Wolff and their clients.

“The MiHpt tool has been our workhorse,” Kulczycky said. “The tills and mixed matrix soils found in the northeast require that the HPT tool is used in combination with the Electrical Conductivity (EC) for soil characterization. We have used the HPT aspect of the probe for resource well siting and the HPT in combination with the thermocouple of the MIP probe to investigate areas of lake water intrusion.”

Since 1969, Parratt-Wolff has been part of more than 13,000 site investigations. Next year, the team will celebrate its 50th anniversary. The company has grown from one drill rig servicing the geotechnical needs of Central New York to three offices and more than 35 drill rigs servicing the environmental and geotechnical drilling needs of the entire East Coast.

“Although we are a drilling contractor by definition, we pride ourselves on serving as drilling consultants to our clients,” Kulczycky said. **“The addition of DI equipment and trained operators to our service offerings furthers our goal as a company of providing technical expertise to our clients.”**

Parratt-Wolff uses their 6712DT to advance 8.25 in. hollow stem augers at a 35° angle for a system installation in northern New Jersey.



MiHpt Operator Matt Padgett uses the 6712DT in an urban setting in North Carolina to collect MiHpt.



MiHpt Operator Jolaan Price is at the controls for Parratt-Wolff while taking their MiHpt tooling off road in Upstate New York.

OIP-Green Successfully Detects Coal Tar Fluorescence

The Optical Imaging Profiler (OIP) is a new direct push photo-logging system developed by Geoprobe® that uses a down hole light source and Complementary Metal-Oxide Semiconductor (CMOS) camera to investigate for fluorescent contaminants through a sapphire window on the side of the probe.

Of course, this probe is for use in soils and unconsolidated formations. The OIP probe was initially developed with an ultraviolet (UV/275nanometer) light emitting diode (LED) for the detection of fuel fluorescence. Several common organic contaminants of concern (coal tars, creosote, bunker fuels) yield inconsistent results under UV light but do fluoresce under green wavelength light. Therefore, Geoprobe® has developed an OIP probe with a green wavelength (525nm) light source (OIP-G).

The downhole camera acquires images of fluorescence at 30 frames per second that are displayed onscreen while logging. The images are analyzed for the percent area of fluorescence (%AF) by a 2-stage digital filter in the OIP software, and one image every 0.05ft (~15mm) is saved to the log file. If there is no fluorescence, the images are dark.

The OIP-G probe includes a dipole electrical conductivity (EC) array for the measurement of bulk formation EC. The EC and %AF logs are displayed onscreen along with the images of fluorescence as the probe is advanced at approximately 2cm/sec by a Geoprobe® unit. We recommend a drive cushion (MN 221775 for GH60 hammer) be used between the hammer and drive cap to optimize probe life.

Geoprobe® coordinated with Gary Richards and Jonathan Stephenson at the Kansas Department of Health & Environment (KDHE) and their contractor GSI Engineering of Wichita, KS, to conduct a test of the OIP-G system at the former manufactured gas plant in Wellington, KS.

The site is underlain by clay rich alluvium with silty to sandy interbeds to a depth of about 30 ft. with Permian Age shale as the bedrock. We completed OIP-G logs at 39 locations to

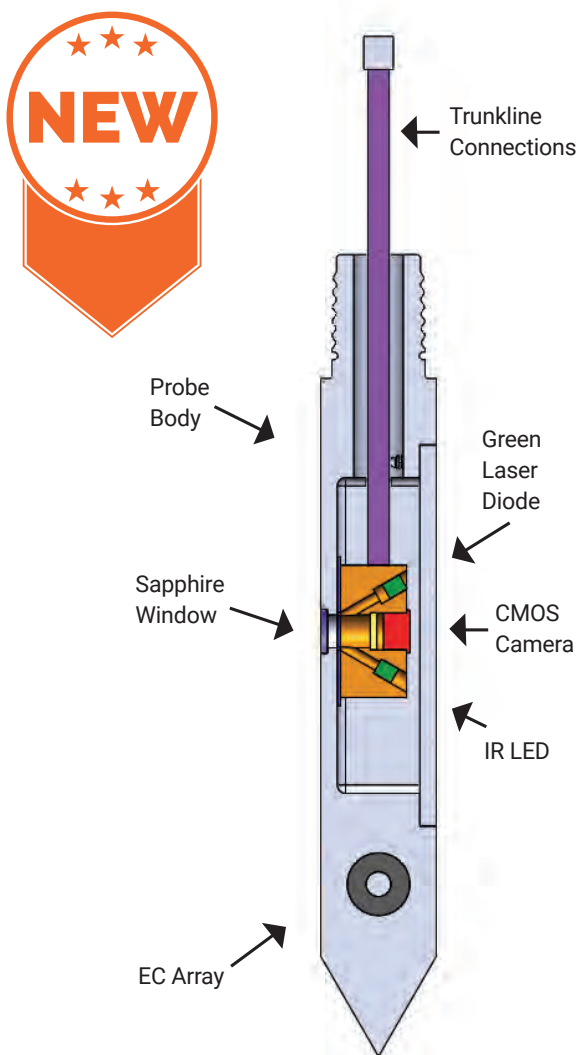

This graphic includes basic components of the OIP-G probe with a 525nm green laser diode light source to induce fluorescence of coal tars, creosote, bunker fuels, and similar heavy hydrocarbons.

depths of up to 33 ft. A log from location KD04 at the Wellington site (shown below) lets you see how a typical OIP-G log looks along with an image showing significant fluorescence. The logs revealed the presence of significant fluorescence at

several locations and depths. Sampling was performed at selected locations and targeted depths based on the fluorescence logs. The samples collected with the DT22 soil coring system were submitted for analysis of polynuclear aromatic hydrocarbons (PAH). Lab analyses revealed the presence of elevated PAH concentrations in most samples.

Importantly, sampling revealed that false positive results (up to 40%AF) were detected at a few locations. Bench tests with dilute hydrochloric acid revealed that these false positive results occurred due to the presence of calcareous minerals. The fluorescence of calcite is well documented. Inspection of the targeted core samples quickly verified the presence of coal tars or calcareous sediments or caliche nodules.

Following field work, cross sections with EC and %AF logs helped to define the presence and distribution of coal tars in the subsurface and identify preferential migration pathways. These results indicate that the OIP-G system will be a useful tool for investigation of coal tar contaminated facilities.



The Wellington, KS, Manufactured Gas Plant (MGP) under construction circa 1886. Note the gas holder in the right foreground. It was destroyed and back-filled after the plant closed.

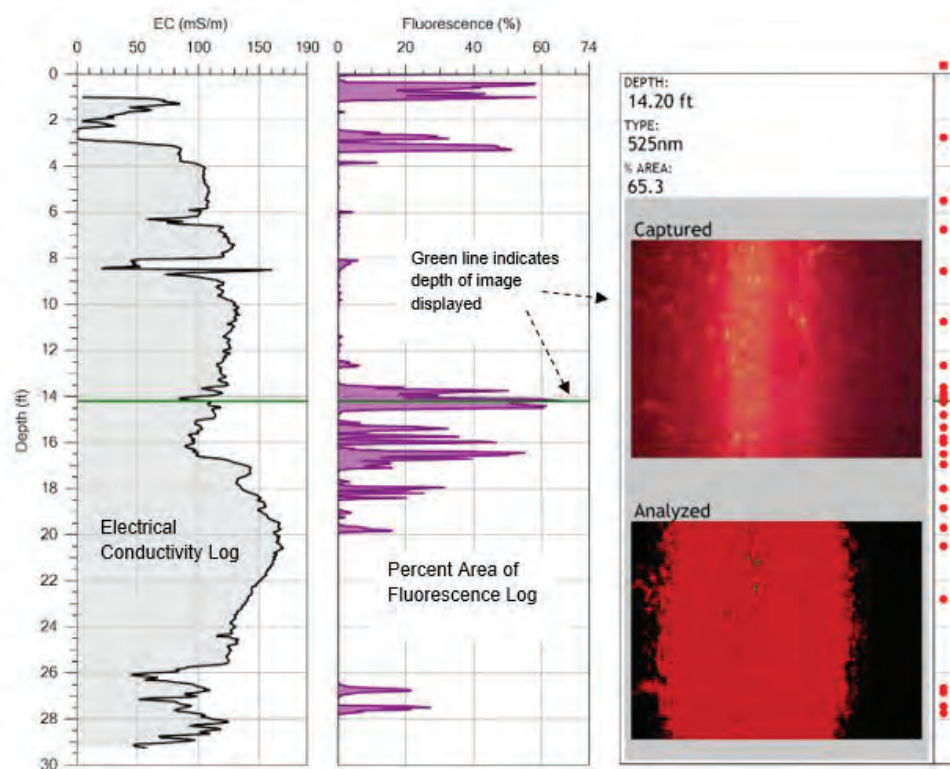

An OIP-G log from the Wellington, KS, former manufactured gas plant (MGP), location KD04. The captured image shows the fluorescent light given off by the coal tars at the indicated depth in the formation. The analyzed image depicts the area of fluorescence that passes the 2-stage digital filter in the software to be classified as contaminant fluorescence. The % Area of fluorescence for this particular image was determined to be 63.5% by the software.



Members of GSI Engineering of Wichita, KS, and the Kansas Department of Health & Environment (KDHE) run an OIP-G log in front of the former Manufactured Gas Plant (MGP) building in Wellington, KS, which has been converted to a railroad museum.

The NEW Direct Image® OIP-G allows coal tars, creosote, and bunker fuels to fluoresce under green wavelength light!



Geoprobe® Geotechnical Tooling

Interlocking Split Spoon is Faster, 2X Stronger, and Lasts Longer

Engineered and built by Geoprobe®, our patented interlocking split spoon saves drillers both time and money. **Our interlocking split spoon is 2X stronger, lasts longer, and is operator-friendly** with fewer turns to put together and take apart thanks to multi-lead threads. It joins the ranks Genuine Geoprobe® products, such as the Macro-Core® and Dual Tube soil sampling systems, and our Screen Point groundwater samplers. It's one more example of our Engineering team's efforts to think outside the box and provide the best possible soil probing and drilling equipment available.



WATCH THE VIDEO:
geoprobe.com/split-spoon



ADAPTABLE
Wide variety of drive heads available

2X THE STRENGTH & DURABILITY
Enhanced material properties result in greater longevity

ASTM STANDARD
Design meets ASTM Standard D1586

STRONGER
The patented interlocking design strengthens the entire sheath

FASTER IN THE FIELD
The interlocking design self-aligns during assembly

ELIMINATES BULGING & BOWING
Sheath stays aligned during impact

OPERATOR-FRIENDLY
Multi-lead threads = fewer turns to put together and take apart

"We have about 2,000 feet of drilling on each spoon and we haven't changed any of the shoes yet, which shocks me. Most traditional split spoons spread apart if you have too much material or you're in sands and gravels. These do not spread apart when you're pulling them out of the hole. We haven't had a spread split spoon since we started running them. They've held up, haven't mushroomed out, they go together easy, and come apart easy. We have a lot of weathered rock here and usually before we start coring we complete two or three 50 overs. So, they're getting a beating and they're handling it very well. I've been very impressed with them."

Eric Hajek • President
Terra Testing Inc. • Washington, PA

"We're quite pleased with it. Timewise it's a lot quicker. It goes together fast and aligns closely. Sometimes you have a little debris in there, so you might have to tap it, but it's not like the traditional split spoons where you literally have to beat the two pieces together. Sampling in hard shales the traditional split spoon bows out in the middle but our Geoprobe® spoon holds its shape. The way it interlocks keeps it from bulging out in the middle. It's nice having the threads on both ends for the (cutting) shoe and top end (drive head). The old school spoons you had to do it a certain way, put the shoe on first and then the back, and the old version doesn't seem to line up as good."

Matt Hanson • Driller
American Engineering Testing Inc. • Sioux Falls, SD



GEOPROBE® LEADS THE WAY: Collecting SPT through 3.75 in. Driven Casing



Mike Carlin
Geoprobe® Tools Group

Our customers have used the 3.75 in. probe rod and DT37 soil sampling system to collect continuous soil samples and SPT samples for several years.

Now, we've made it possible to collect SPT data via split spoon sampler and automatic drop hammer within the same 3.75 in. driven casing.

With some small tweaks to the system, operators now have access to two valuable pieces of information – continuous soil samples and SPT samples.

This system is applicable anywhere driven casing can be advanced with a Geoprobe® machine.

While ASTM D1586 makes no mention of a driven casing method, our preliminary findings have found it to be a promising method for collecting SPT data.

We will continue to conduct field trials, collect scientific data with this method, and work with our friends at ASTM to better educate engineers, consultants, and drillers on best practices regarding the collection of SPT data.

IT'S FAST, EASY & SAFE!

The example on the left depicts the standard DT37 Dual Tube Soil Sampling System being advanced to collect a continuous soil sample. The example on the right depicts using the same 3.75 in. casing to collect SPT samples ahead of the driven casing.

Join the "elite cadre of probists" who belong to ...

Geoprobe® '100' Club

Exclusive to Geoprobe® machine owners who push 100 feet or beyond!

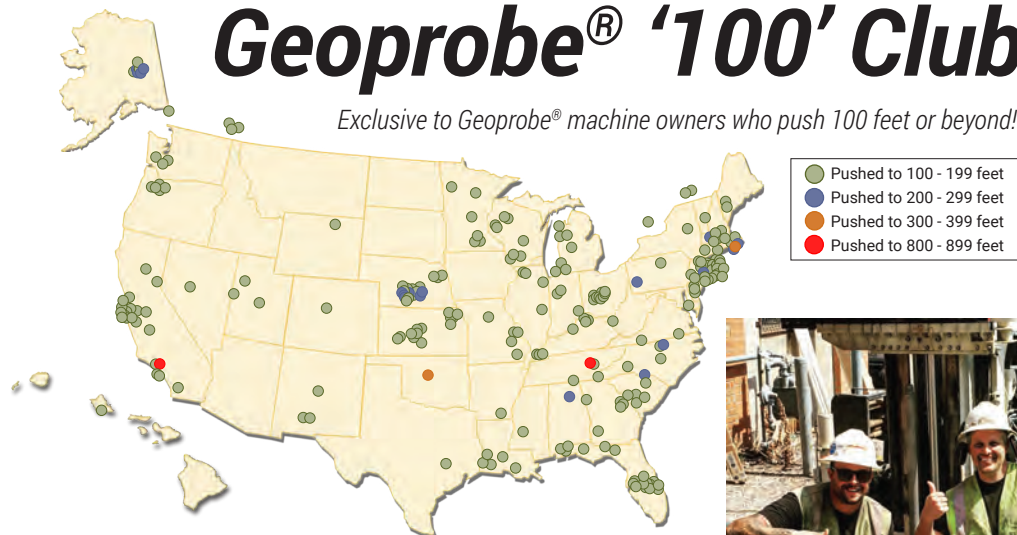

- Pushed to 100 - 199 feet
- Pushed to 200 - 299 feet
- Pushed to 300 - 399 feet
- Pushed to 800 - 899 feet

104 ft. SGS North America - New Jersey

FIELD NOTES
 Field Team: Nick Calise
 Field Site: Price Landfill
 Depth/Date: 104 ft. / February 5, 2018
 Geoprobe® Owner: SGS North America
 Field Data: 7822DT. HPT sampling.



101 ft. Horizon Construction & Exploration – Wisconsin

FIELD NOTES
 Field Team: Greg Wester and Adam Sweet
 Field Site: Baraboo, WI
 Depth/Date: 101 ft. / August 16, 2017
 Geoprobe® Owner: Horizon Construction & Exploration, Fredonia, WI
 Field Data: Model 3230DT. Used DT-22 to take soil samples the entire way and then set a 1 in. well at 101 ft. pulling water samples as they pulled back every 5 ft. for 40 ft. Upon completion of both soil and water sampling, grouted the entire boring from 101 ft. back to surface to completely abandon the boring to code. "It went amazingly well and the client was very satisfied."



103 ft. Geo Lab – Georgia

FIELD NOTES
 Field Team: Edward Wayman (pictured) & Charles Black (not pictured)
 Field Site: Salley, SC
 Depth/Date: 103 ft. / July 19, 2017
 Geoprobe® Owner: Geo Lab Probing Services, Atlanta, GA
 Field Data: Model 7720DT, 1-in. PVC monitoring well installed using a DT22 soil sampler followed by 4-in. solid flight augers.



128 ft. Cascade Drilling – South Carolina

FIELD NOTES
 Field Team: Joshua Justice (pictured), Richard Mooney & Matt Malin (not pictured)
 Field Site: Savannah River Site, Aiken, SC
 Depth/Date: 128 feet / January 11, 2018
 Geoprobe® Owner: Cascade Drilling, New Ellenton, SC
 Field Data: Model 7822DT.



227 ft. Enviroprobe Integrated Solutions – West Virginia

FIELD NOTES
 Field Team: Jim Fore, Brandon Conley and Lewis Eplin
 Field Site: Pittsburgh, PA
 Depth/Date: 227 ft. / August, 2017
 Geoprobe® Owner: Enviroprobe Integrated Solutions, Nitro, WV
 Field Data: Model 7822DT, NQ tooling working on an EQT pipeline, just north of Pittsburgh, PA.



217 ft. Geo Lab – Georgia

FIELD NOTES
 Field Team: Cody Hart, Phillip Ricker & Perry Suzettis (not pictured)
 Field Site: NE Alabama
 Depth/Date: 217 ft / August, 2017
 Geoprobe® Owner: Geo Lab Probing Services, Atlanta, GA
 Field Data: Model 7822DT, NQ Wireline Rock Coring in dozens of boreholes greater than 100 ft. in depth.



120 ft. Penecore Drilling – California

FIELD NOTES
 Field Team: George Valero, Wilfrido Guillen & Jorge Ornelas
 Field Site: Strawberry Valley, CA
 Depth/Date: 120 ft. / July 2017
 Geoprobe® Owner: Penecore Drilling, Woodland, CA
 Field Data: Model 8040DT.



Drillers choose 1.75 in. probe rod for size, durability

Our NEW Geoprobe® 1.75 in. probe rods are stronger, last longer, and can be used for multiple applications. As a result, they've become the rod of choice for many drillers.

- The ID (0.75 in.) makes running larger DI trunklines easier (MIP-HPT, MIP-HTL and OIP-HPT).
- Larger, multi-lead threads increase longevity
- Larger threads seal better, even without orings, making them ideal for discreet vertical profile water sampling applications
- Meets ASTM D1586 for Standard Penetration Testing (SPT)

"We've been utilizing the 1.75 in. Geoprobe® rod for Direct Image® tooling since their release with great success. We have encountered at minimum, double the life span versus the 1.5 in. rods. We have run the new 1.75 in. rods thousands of feet in conjunction with Mi-Hpt, HPT, OIP, OiHpt and EC with depths of 80 ft. plus. We have not experienced a probe loss due to broken rod joints, which we experienced in the past using 1.5 in. rods. Even when we hammered on an OiHpt probe well past normal and sane refusal, the probe and rods were brought back without any thread damage whatsoever. We have replaced a few with worn threads from our original batch but have not had to replace any due to bending or joint deformation. I highly recommend the 1.75 in. rod. It will be my only choice of rod for the vast array of Direct Image® tooling we operate – That is until Geoprobe® unveils something new and approved, which they usually do!"

Jonathan Wiley • Direct Imaging Manager
 Stock Drilling • Ida, MI

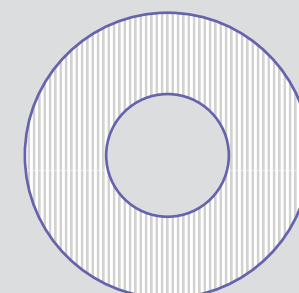

MN: 202248 - 48 in.
 MN: 201682 - 60 in.
1.5 in. OD
 0.625 in. ID
 5.0 lbs./ft

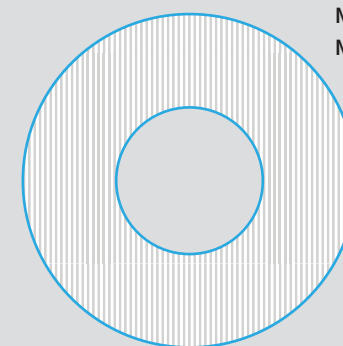

MN: 220746 - 48 in.
 MN: 220032 - 60 in.
1.75 in. OD
 0.75 in. ID
 6.8 lbs./ft

Actual size of the cross section view.

Geoprobe® Opens Regional Service Center in Florida



Darren Stanley, Geoprobe® Service Manager, shares exciting news...

One of our main company objectives at Geoprobe® is to **PROVIDE TOP SERVICE IN THE DRILLING INDUSTRY**. For the last few years we've been considering how we could take Geoprobe® service to the next level. When DRILLMAX®, located in Ocala, Florida, joined Geoprobe®, it created a natural opportunity to leverage existing shop space specifically for Geoprobe® rig service. **This is a big step for us and we are excited to get this new venture started.** The initial focus of this location will be setting up a service shop. This shop will be a well-equipped location where customers can bring their Geoprobe® machine for routine maintenance or more in-depth repairs.

Success in this new venture would not be possible without an experienced service technician. After 10 years of working as a valuable member of our Salina based Geoprobe® Service Team, Todd Ewing and family offered to relocate to Ocala, Florida. (Thank you, Todd.) Todd's new role will be hands-on — in the shop — making sure Geoprobe® customers are provided the best service in the drilling industry.

For customers in the southeast United States, expect to receive more details related to the NEW GEOPROBE® SERVICE CENTER soon.



Darren Stanley
Geoprobe®
Service Manager



Todd Ewing
Geoprobe®
Service Specialist



Doors Open June 2018

FOR MORE INFORMATION ON WHAT YOU HAVE READ IN THIS ISSUE, CONTACT US AT

WWW.GEOPROBE.COM • 785-825-1842

Geoprobe Systems®
1835 Wall Street • Salina, Kansas 67401

Change Service Requested

PRSR STD
U.S. Postage
PAID
SALINA, KS 67401
Permit No. 122